

# EVA Expandable Vertical Array

EVA-2082S, EVA-1151D, EVA-2151D

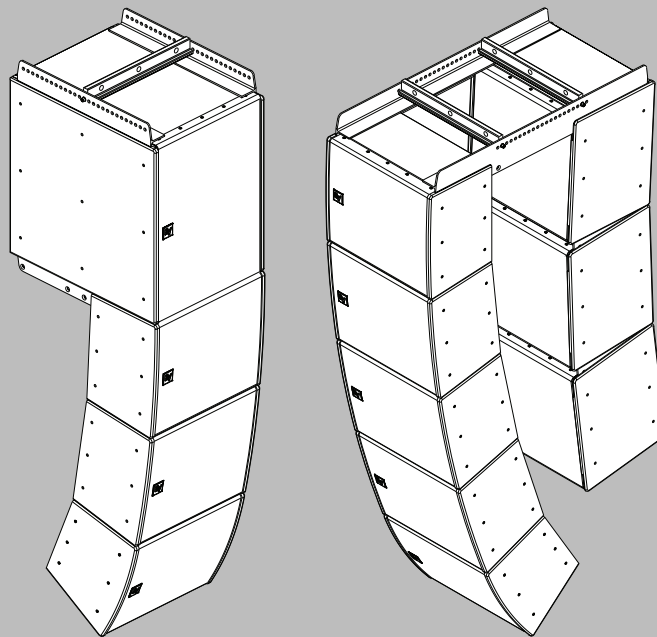



## Table of contents

<b>1</b>	<b>Rigging-safety warning</b>	<b>4</b>
<b>2</b>	<b>Applicable products</b>	<b>5</b>
<b>3</b>	<b>Introduction</b>	<b>8</b>
<b>3.1</b>	Dimensions	<b>9</b>
<b>3.2</b>	Features	<b>12</b>
<b>3.3</b>	Accessories	<b>14</b>
<b>4</b>	<b>Tool list</b>	<b>16</b>
<b>5</b>	<b>Designing an array</b>	<b>17</b>
<b>5.1</b>	Designing and optimizing arrays	<b>17</b>
<b>5.2</b>	Typical number of arrays	<b>17</b>
<b>6</b>	<b>Preparing modules for installation</b>	<b>18</b>
<b>6.1</b>	Recommended preflight procedures	<b>18</b>
<b>6.2</b>	Module configuration	<b>18</b>
<b>7</b>	<b>Rigging system</b>	<b>22</b>
<b>7.1</b>	Overview of the flying system	<b>22</b>
<b>7.2</b>	Deciding which grid configuration to use with an array	<b>23</b>
<b>7.2.1</b>	Standard grid with or without second spreader bar	<b>23</b>
<b>7.2.2</b>	Extended grid with or without second spreader bar	<b>25</b>
<b>7.2.3</b>	Coupler grid with or without second spreader bar	<b>25</b>
<b>7.2.4</b>	Use of two standard grids	<b>26</b>
<b>7.2.5</b>	EVA-1151D tie plates	<b>27</b>
<b>7.3</b>	Assembling and flying an array	<b>29</b>
<b>8</b>	<b>Rigging-strength ratings and safety factors</b>	<b>31</b>
<b>8.1</b>	Working-load limit and safety factor definitions	<b>31</b>
<b>8.2</b>	Structural-rating overview	<b>31</b>
<b>8.3</b>	Special rules when flying EVA-2151D subwoofer modules	<b>32</b>
<b>8.4</b>	Simplified structural-rating guidelines	<b>33</b>
<b>8.5</b>	Structural rating charts	<b>34</b>
<b>8.6</b>	Structural-analysis procedures	<b>39</b>
<b>9</b>	<b>Rigging inspection and precautions</b>	<b>40</b>
<b>10</b>	<b>References</b>	<b>41</b>
<b>10.1</b>	Rigging (printed)	<b>41</b>
<b>10.2</b>	Mechanical engineering (printed)	<b>41</b>
<b>10.3</b>	Rigging (websites)	<b>41</b>

# 1 Rigging-safety warning

**Warning!**

Read and fully understand the manual and all safety instructions before attempting to suspend this loudspeaker.

Qualified professionals must carry out suspension and installation.

Follow all applicable local laws and regulations. Incorrect or improper suspension could expose persons to serious injury or death.

Carefully inspect loudspeakers and associated hardware for defects or signs of damage before proceeding to suspend the speakers. Inspect all components at least once per year or as local laws and regulations require. Inspection shall include visual survey of all corners and load bearing surfaces for signs of cracking, water damage, de-lamination, or any other condition that may decrease the strength of the loudspeaker enclosure. If any parts are damaged or suspect, or if there is any doubt as to the proper functioning and safety of the items, stop using them immediately.

It is the responsibility of the person installing the assembly to make sure the wall, ceiling, structure, and any attachments are capable of supporting all objects suspended overhead. Never modify Electro-Voice loudspeakers or rigging components or use a partial assembly of rigging components.

Only use rigging components with the loudspeaker models they are designed for. Any hardware not provided by Electro-Voice is the responsibility of others.

Electro-Voice assumes no liability for any damage or personal injury resulting from improper use, installation, or operation of the product.

**Warning!**

Always attach a secondary support mechanism with correctly load rated equipment when speakers are suspended overhead.

In case of failure of the main attachment, the speaker must be prevented from falling without dropping or swinging by a significant amount.

**Warning!**

Arrays designed for outdoor use must take into account environment effects such as wind loads, snow or any other condition that can add external forces to the array. Always use a qualified professional to certify outdoor arrays for safety to local environmental conditions.

## 2 Applicable products

This manual is applicable to these products:

CTN	Description
EVA-2082S/906-BLK	Dual 8-in. two-way, 90° x 6°, black
EVA-2082S/906-WHT	Dual 8-in. two-way, 90° x 6°, white
EVA-2082S/906-PIB	Dual 8-in. two-way, 90° x 6°, black, weather resistant
EVA-2082S/906-PIW	Dual 8-in. two-way, 90° x 6°, white, weather resistant
EVA-2082S/906-FGB	Dual 8-in. two-way, 90° x 6°, black, weather resistant fiberglass
EVA-2082S/906-FGW	Dual 8-in. two-way, 90° x 6°, white, weather resistant fiberglass

**Table 2.1:** EVA-2082S/906 modules

CTN	Description
EVA-2082S/920-BLK	Dual 8-in. two-way, 90° x 20°, black
EVA-2082S/920-WHT	Dual 8-in. two-way, 90° x 20°, white
EVA-2082S/920-PIB	Dual 8-in. two-way, 90° x 20°, black, weather resistant
EVA-2082S/920-PIW	Dual 8-in. two-way, 90° x 20°, white, weather resistant
EVA-2082S/920-FGB	Dual 8-in. two-way, 90° x 20°, black, weather resistant fiberglass
EVA-2082S/920-FGW	Dual 8-in. two-way, 90° x 20°, white, weather resistant fiberglass

**Table 2.2:** EVA-2082S/920 modules

CTN	Description
EVA-2082S/126-BLK	Dual 8-in. two-way, 120° x 6°, black
EVA-2082S/126-WHT	Dual 8-in. two-way, 120° x 6°, white
EVA-2082S/126-PIB	Dual 8-in. two-way, 120° x 6°, black, weather resistant
EVA-2082S/126-PIW	Dual 8-in. two-way, 120° x 6°, white, weather resistant
EVA-2082S/126-FGB	Dual 8-in. two-way, 120° x 6°, black, weather resistant fiberglass

CTN	Description
EVA-2082S/126-FGW	Dual 8-in. two-way, 120° x 6°, white, weather resistant fiberglass

**Table 2.3:** EVA-2082S/126 modules

CTN	Description
EVA-2082S/1220-BLK	Dual 8-in. two-way, 120° x 20°, black
EVA-2082S/1220-WHT	Dual 8-in. two-way, 120° x 20°, white
EVA-2082S/1220-PIB	Dual 8-in. two-way, 120° x 20°, black, weather resistant
EVA-2082S/126-PIW	Dual 8-in. two-way, 120° x 20°, white, weather resistant
EVA-2082S/126-FGB	Dual 8-in. two-way, 120° x 20°, black, weather resistant fiberglass
EVA-2082S/126-FGW	Dual 8-in. two-way, 120° x 20°, white, weather resistant fiberglass

**Table 2.4:** EVA-2082S/1220 modules

CTN	Description
EVA-1151D-BLK (discontinued)	Single 15-in. subwoofer, black
EVA-1151D-WHT (discontinued)	Single 15-in. subwoofer, white
EVA-1151D-PIB (discontinued)	Single 15-in. subwoofer, black, weather resistant
EVA-1151D-PIW (discontinued)	Single 15-in. subwoofer, white, weather resistant
EVA-1151D-FGB (discontinued)	Single 15-in. subwoofer, black, weather resistant fiberglass
EVA-1151D-FGW (discontinued)	Single 15-in. subwoofer, white, weather resistant fiberglass

**Table 2.5:** EVA-1151D subwoofer modules (discontinued)

CTN	Description
EVA-2151D-BLK	Dual 15-in. subwoofer, black
EVA-2151D-WHT	Dual 15-in. subwoofer, white
EVA-2151D-PIB	Dual 15-in. subwoofer, black, weather resistant

<b>CTN</b>	<b>Description</b>
EVA-2151D-PIW	Dual 15-in. subwoofer, white, weather resistant

**Table 2.6:** EVA-2151D subwoofer modules

## 3 Introduction

The Electro-Voice Expandable Vertical Array (EVA) line-array modules represent an important step in line-array technology for small- and medium-scale fixed-installation sound reinforcement.

The four base models are designed to simplify the physical assembly of a line array. Also, arrays of EVA full-range modules are designed to be powered from one amplifier channel. Sophisticated passive networks provide the necessary crossover and EQ functions.

The individual loudspeaker drivers, Hydra™ waveform converters, acoustic waveguides, enclosures and rigging hardware were all designed specifically for the EVA product line. The goal is to achieve the highest acoustic output with the highest fidelity and produce a precise wavefront from each element to achieve state-of-the-art line-array performance.

The EVA subwoofer modules complement both the appearance and performance of the EVA full-range modules in applications where additional low-frequency output is required from a flown array.

EVA loudspeaker arrays present an affordable option for projects that require a line array approach, but have limited budgets. At the same time, the performance of fully passive EVA systems rivals that of more expensive and complex line arrays. EVA was designed for outstanding sound quality with only minor equalization for room compensation, without any speaker-specific settings.

But Electro-Voice also offers EVA loudspeaker settings that can be loaded into Dynacord amplifiers and processors by using SONICUE System Software. The settings add protective limiters to reduce the risk of loudspeaker failure, and allow higher drive levels.



### 3.1 Dimensions

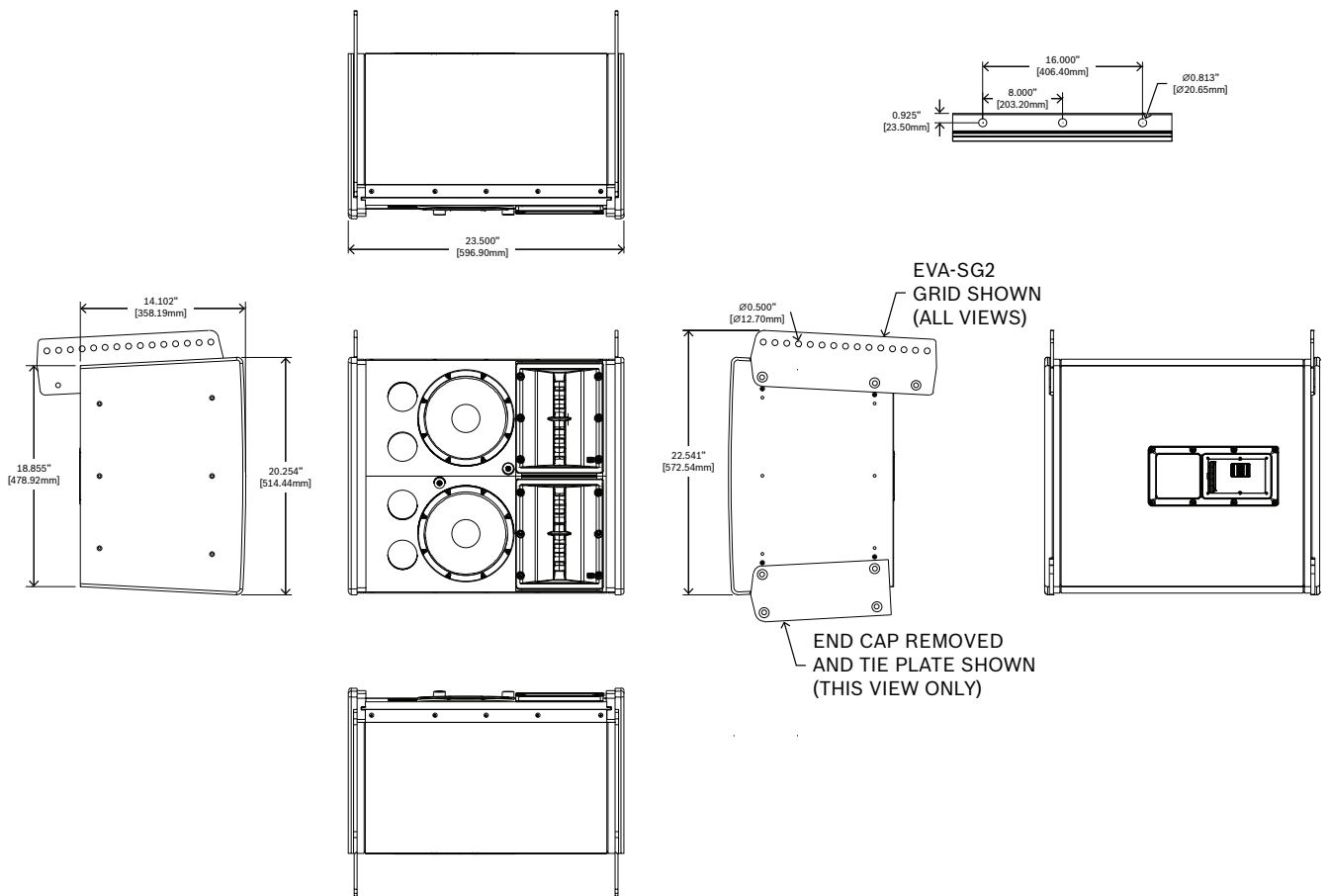

**Figure 3.1:** EVA-2082S/906 or EVA-2082S/126 dimensional views and spreader bar attach holes

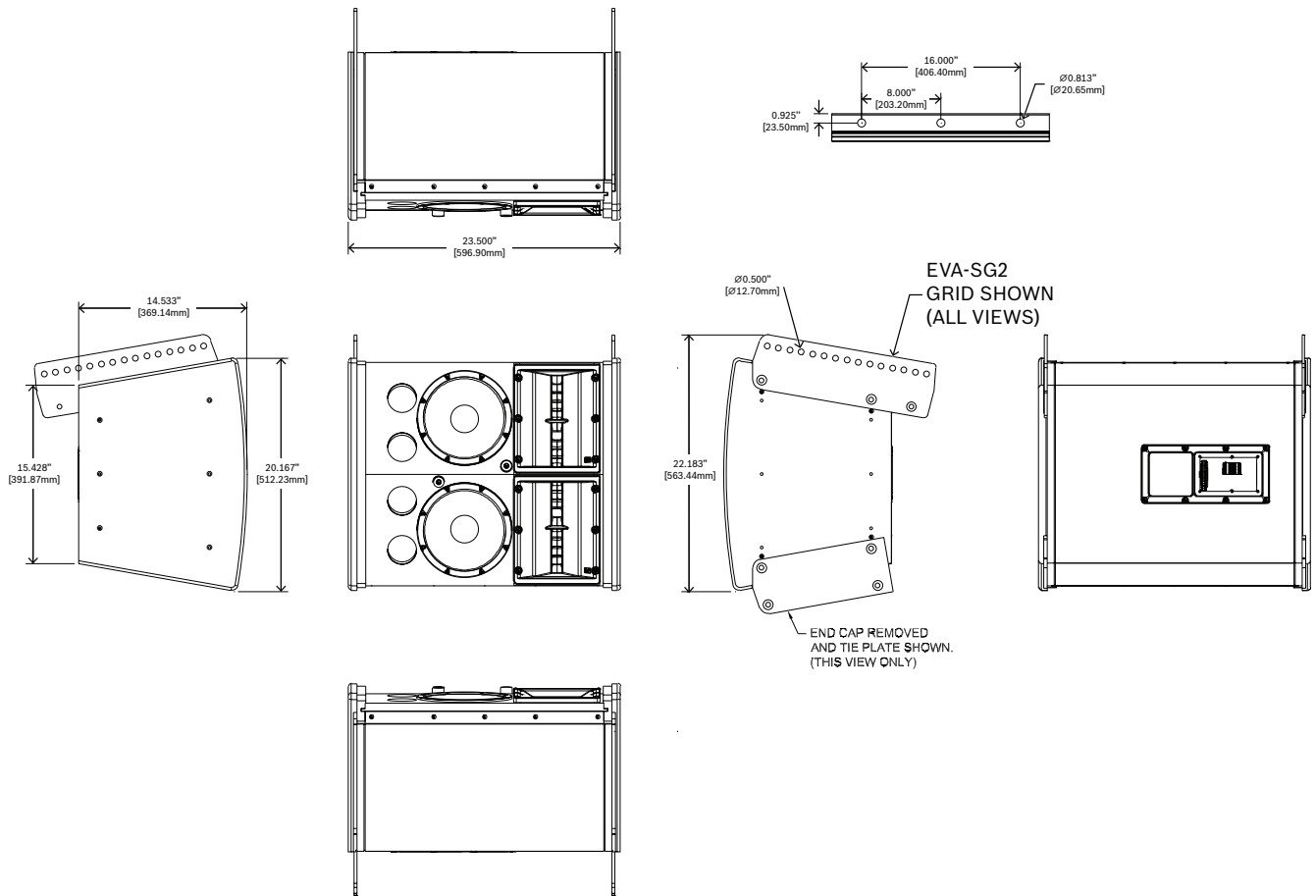

**Figure 3.2:** EVA-2082S/920 or EVA-2082S/1220 dimensional views and spreader bar attach holes

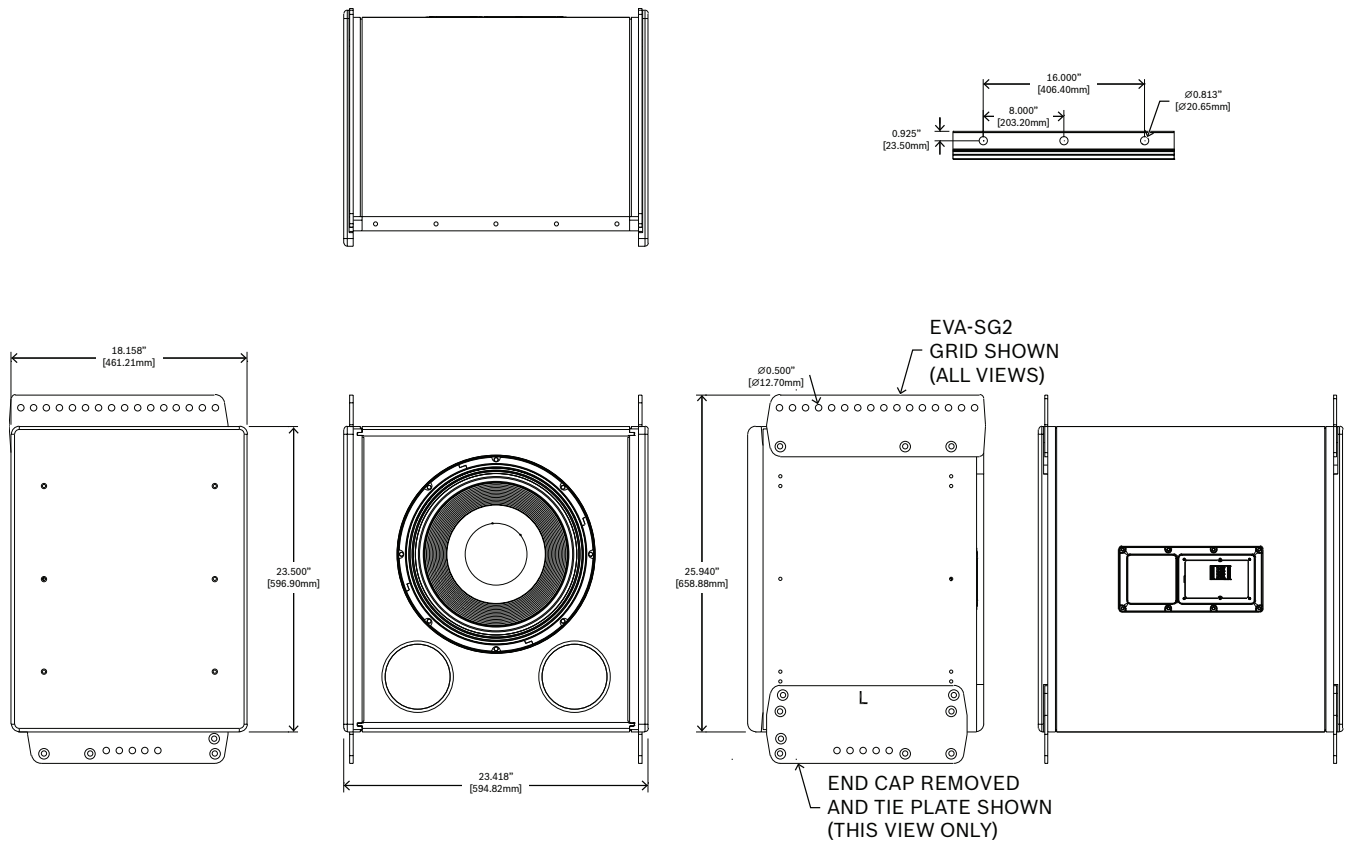

**Figure 3.3:** EVA-1151D (discontinued) dimensional views and spreader bar attach holes

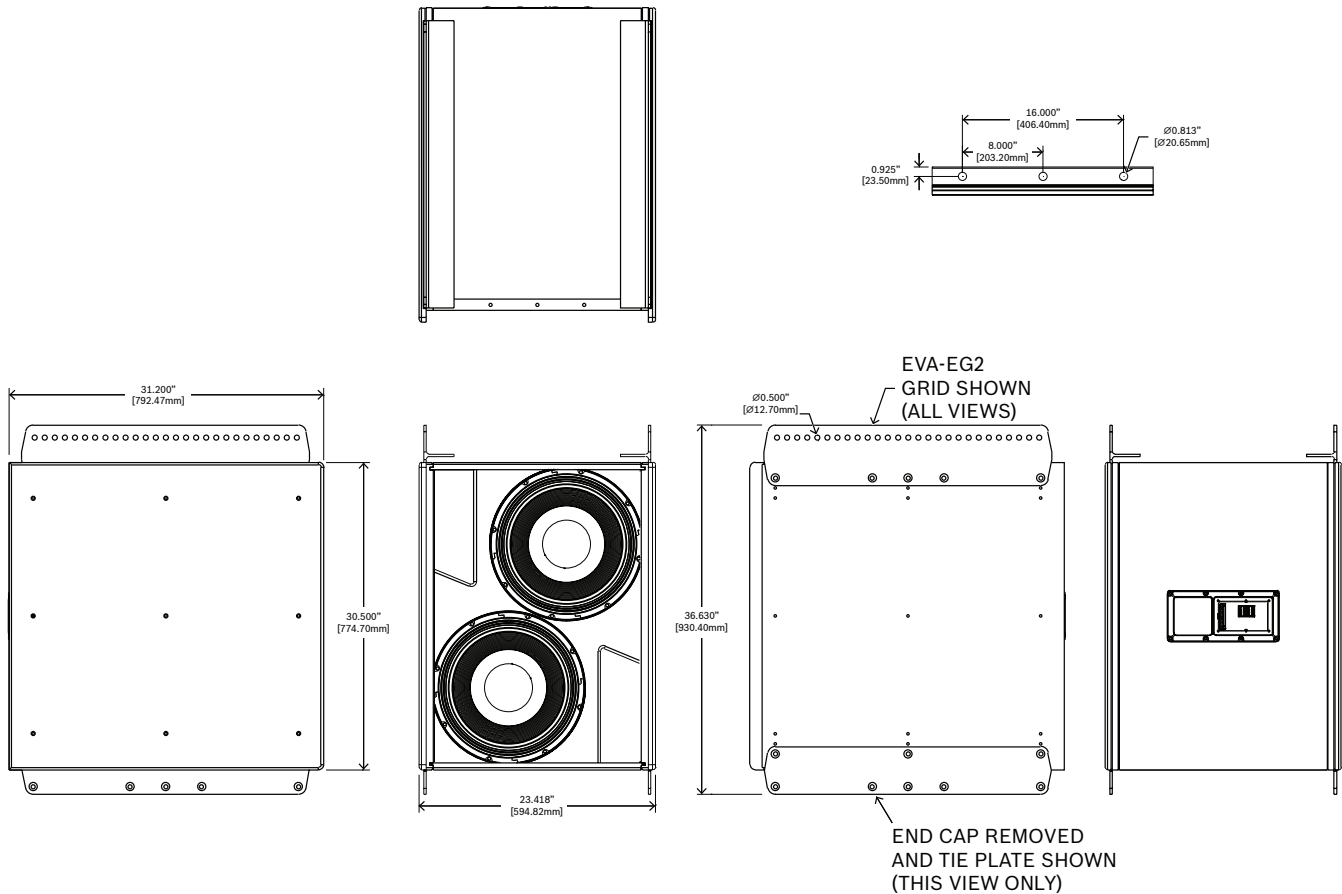

**Figure 3.4:** EVA-2151D dimensional views and spreader bar attach holes

## 3.2 Features

Although the EVA full-range modules are not the same, their acoustic polar responses are substantially symmetrical. You can construct stereo-left and -right arrays or left-center-right arrays with the modules in their normal right-side-up orientation. Alternatively, the module attachment points are such that mirror-image left-right arrays can be made by constructing one array with its modules turned upside down.

Each EVA full-range module contains two separate, vertically stacked line-array elements splayed within the module at one-half the included vertical angle of the vertically trapezoidal enclosure. The two elements of each module consist of two vertically stacked EVS2008 8-inch (203 mm) LF drivers (one per element) and two pairs of DH2005 1.25-inch-diaphragm (32 mm) HF drivers (one pair per element). Each HF driver pair is mounted on a Hydra™ waveform converter, the two of which are vertically stacked and splayed with their respective elements. Each module functions as one self-contained zone within an array. The added benefit of the internal shading network attenuates the upper or lower HF driver pair by 3 dB to help smooth transition between zones when needed.

### **EVA-2082S/906 full-range module**

EVA-2082S/906 is a two-way, LF/HF line-array module with a 90° horizontal x 6° vertical coverage pattern (for long throws) and passive crossover/HF-shading/EQ network. The enclosure is trapezoidal in the vertical plane with a 6° total included angle. The two line-array elements contained in the module are vertically splayed by 3°.

**EVA-2082S/920 full-range module**

EVA-2082S/920 is a two-way, LF/HF line-array module with a 90° horizontal x 20° vertical coverage pattern (for short throws) and passive crossover/HF-shading/EQ network. The enclosure is trapezoidal in the vertical plane with a 20° total included angle. The two line-array elements contained in the module are vertically splayed by 10°.

**EVA-2082S/126 full-range module**

EVA-2082S/126 is a two-way, LF/HF line-array module with a 120° horizontal x 6° vertical coverage pattern (for long throws) and passive crossover/HF-shading/EQ network. The enclosure is trapezoidal in the vertical plane with a 6° total included angle. The two line-array elements contained in the module are vertically splayed by 3°.

**EVA-2082S/1220 full-range module**

EVA-2082S/1220 is a two-way, LF/HF line-array module with a 120° horizontal x 20° vertical coverage pattern (for short throws) and passive crossover/HF-shading/EQ network. The enclosure is trapezoidal in the vertical plane with a 20° total included angle. The two line-array elements contained in the module are vertically splayed by 10°.

**EVA-AM attenuation module**

The EVA-AM attenuation module mounts on the inside of an EVA-2082S input panel, and attenuates the entire module by 3, 6 or 9 dB. The nominal impedance of an EVA-2082S module is 16 ohms. Up to six paralleled EVA-2082S modules can be driven from a single amplifier channel capable of driving a 2.7-ohm nominal impedance (16 ohms ÷ 6 modules = 2.7 ohms). If at least two of the modules have the optional EVA-AM attenuation modules installed, a single amplifier channel capable of driving a 2.3-ohm nominal impedance can drive up to eight paralleled EVA-2082S modules.

**EVA-1151D single subwoofer module (discontinued)**

EVA-1151D is a compact single 15-inch subwoofer module capable of being flown either above or behind an EVA full-range array. EVA-1151D is a rectangular unit with special tie plates that allow for assembly with either 0° or 5° of splay between modules. It may also be used in a stand-alone subwoofer array or ground-stacked.

**EVA-2151D dual subwoofer module**

EVA-2151D is a large rectangular dual 15-inch subwoofer module designed for use only at the top of an EVA full-range array. It may also be used in a stand-alone subwoofer array or ground-stacked.

Both subwoofers use the DVX3159A 15-inch (381 mm) woofer designed specifically for subwoofer duty, providing reliable low-frequency performance at high SPL levels with low distortion and solid impact.

**Notice!**

Subwoofer modules do not have internal passive crossovers and require an active crossover and dedicated amplifier channel(s) for proper operation.

The standard EVA indoor versions are finished in tough EVCoat™. All EVA modules (except EVA-2151D) are available in two levels of weather resistance:

- Fiberglass (FG) versions like EVA-2082S/906-FGB are designed for full weather exposure. They feature a fiberglass-finished enclosure, stainless-steel three-layer hydrophobic grille and the CDG dual-gland-nut input-panel cover.

- Permanent Install (PI) versions like EVA-2082S/906-PIB are rated for indirect outdoor exposure only in protected areas, such as under a roof overhang. They feature a stainless-steel three-layer hydrophobic grille and the CDG dual-gland-nut input-panel cover on an enclosure finished in standard EVCoat.

External fasteners on all EVA systems are stainless steel.

All EVA modules are available in black or white and are supplied with the hardware necessary to fasten one module to another. Two cosmetic side cover panels give the finished array a smooth and uncluttered appearance. The end caps on the fiberglass versions are also finished in fiberglass. Black is indicated by BLK or B at the end of the complete model number and white is indicated by WHT or W at the end of the complete model number. For example EVA-2082S/906-BLK and EVA-2082S/906-PIB.

### 3.3

## Accessories

### EVA-SG2 standard grid

EVA-SG2 is a standard grid for typical down angles with small arrays, or top and bottom suspension for extreme down angles in large arrays of EVA-1151D subwoofer (discontinued) and/or EVA-2082S full-range modules.

Not for use with EVA-2151D subwoofer.

### EVA-EG2 extended grid

EVA-EG2 is an extended grid for extreme down angles in small to medium arrays and typical down angles in large arrays. EVA-EG2 is the only grid for flying EVA-2151D subwoofers.

### EVA-CG coupler grid (discontinued)

EVA-CG is a coupler grid for flying EVA-1151D subwoofer modules (discontinued) behind an EVA full-range array.



#### Notice!

The three different grid options (EVA-SG2, EVA-EG2 and EVA-CG) are sold separately. Consult the PREVIEW Loudspeaker Software for proper grid selection.



#### Caution!

Series 2 grids (EVA-SG2, EVA-EG2) are required to fly EVA subwoofer modules. Older grids (EVA-SG, EVA-EG) are used for flying EVA full-range modules only.

### EVA-GXB extra spreader bar

EVA-GXB is an optional second spreader bar for EVA grids, to be used when two-point front-to-back hangs are required.



#### Notice!

The need to maintain sufficient pressure on the forward rigging point limits the amount of down angle available with the standard EVA grids (EVA-SG or EVA-SG2) in this configuration.

### CDG cover plate

An optional dual-gland-nut input panel cover is used to protect the input connections from water.

**Notice!**

The CDG dual-gland-nut cover is supplied with the weather-resistant versions of EVA modules.

---

**CSG cover plate**

An optional single-gland-nut input panel cover is used to protect the input connections from water.

**CDNL4 cover plate**

An optional input-panel cover equipped with dual Neutrik Speakon® NL4 connectors is used to provide a quick disconnect alternative to the standard Phoenix screw-terminal input connectors.

## 4 Tool list

Tools required to assemble an EVA array:

- Phillips #2 screwdriver for attaching cosmetic end panels.
- 6-mm Allen (hex) wrench for attaching tie plates and assembling grids.
- 3/16-inch flat-blade screwdriver for attaching signal wires to input-panel connectors.



## 5 Designing an array



### Warning!

When flown in the same column with full-range modules from an EVA-SG2 or EVA-EG2 grid, subwoofers must always be at the top of the array.

### 5.1 Designing and optimizing arrays

The total included vertical angles of the EVA modules in side view (6° for long-throw and 20° for short-throw) were determined after analyzing array simulations in a wide range of venues. Optimal distance for uniform front-to-back coverage is 100 ft ±25 ft.

Use Electro-Voice PREVIEW Loudspeaker Software to design and optimize EVA arrays for a specific situation. You can download the latest version of PREVIEW from the EV website.

A good rule of thumb for aiming a three- or four-box array in a venue with a flat floor is to have a line running through the intersection of the top two modules intersect the head of the person in the last row.

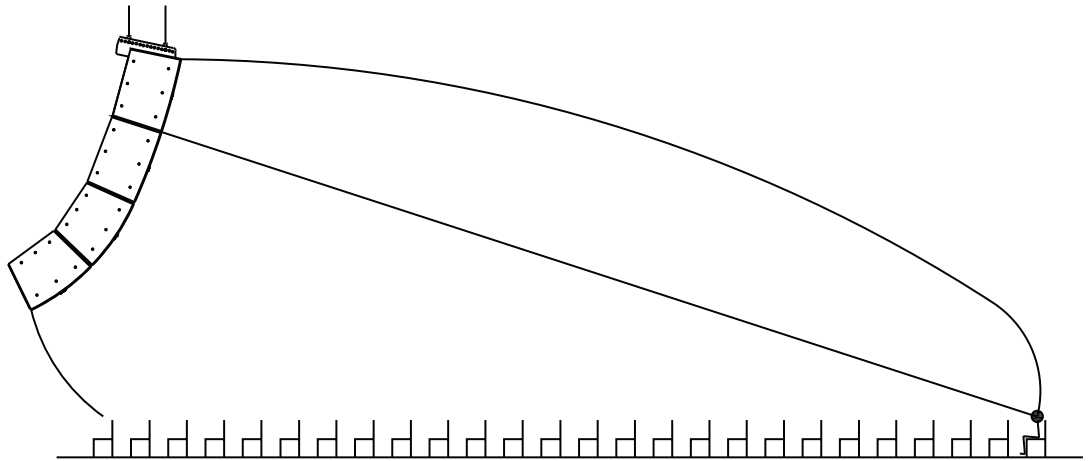

**Figure 5.1:** Rule-of-thumb for aiming three- and four-module EVA arrays

The Array Optimizer function in PREVIEW Loudspeaker Software determines the best aiming angle for any valid combination of EVA-2082 modules.

GLL files for EVA simulations in EASE or EASE Focus are posted for download from the Electro-Voice website. You can predict the coverage of EVA arrays in these software applications, but you cannot validate rigging configurations.

### 5.2 Typical number of arrays

Line-array systems usually consist of vertical columns of multiple independent line-array elements. The most common implementation is a sound reinforcement system with two columns (left and right). Additional columns cover different seating sections of a venue, such as seating areas that wrap around the side or back of a stage. Left-center-right configurations use the center channel for speech.

A single array can provide good coverage in some venues. A variation of such a monaural system is the exploded array, where two or more widely spaced (approximately 10 ft or more) arrays provide the horizontal coverage required. Distributed systems, such as in an arena, use a large number of arrays.

## 6 Preparing modules for installation

### 6.1 Recommended preflight procedures

For any sound system, certain checks made at the installer's place of business can prevent expensive on-site delays. A short-list follows, and sets the stage for proper array performance:

1. Unpack all loudspeakers in the shop.
2. Check for proper model numbers.
3. Check the overall condition of the loudspeakers.
4. Check for continuity at the loudspeaker inputs.

It is a good idea, once on-site and the loudspeakers are connected, to check again for continuity at the power-amplifier end.

### 6.2 Module configuration

While modeling an EVA system in the PREVIEW Loudspeaker Software, you can shade the loudspeakers with the high-frequency attenuation card in the input cup, or with optional attenuation modules. You need to perform this shading manually when the system is rigged and suspended.



#### Notice!

It is possible to complete shading adjustments and installation of attenuation modules at the installer's shop. Make certain that EVA modules are properly identified to avoid misassembly of the array in the field.

#### Use of high-frequency shading

An EVA HF shading switch card comes pre-inserted in the "Center = Both @ 0 dB" position, indicating no shading of either HF element.

#### To attenuate the top HF element:

- Remove the switch card by drawing it toward you using the central finger hole. It is possible to remove the switch with the end of a flat-blade screwdriver. Place the blade end in the switch hole and use the adjacent edge of the input panel as a fulcrum. A small recess in the edge of the input panel opposite to the hole in switch card facilitates this operation.



**Figure 6.1:** EVA input panel as supplied, with the high-frequency (HF) shading switch card in its central, 0 dB position

**To shade the upper HF element by 3 dB:**

- ▶ Reinsert the switch card one step higher.



**Figure 6.2:** EVA input panel, with the switch card inserted to shade the upper HF element by 3 dB

**To shade the lower HF element:**

- ▶ Reinsert the switch card one step lower.



**Figure 6.3:** EVA input panel, with the switch card inserted to shade the lower HF element by 3 dB

**Use of optional attenuation modules**

Some array designs also use one or more of the optional EVA-AM attenuation modules.

**Notice!**

The EVA-AM is for use only with EVA-2082S full-range modules.

**To attach the EVA-AM attenuation modules to the inside of the input-panel assembly:**

1. Using a Phillips #2 screwdriver, remove the eight screws holding the input panel in place. The cable assembly that connects the green PC board of the input panel to the crossover/equalizer network inside the EVA module is long enough to allow the input-panel assembly to rest on a flat surface close to the EVA module. If necessary, disconnect the crossover/equalizer cable temporarily.

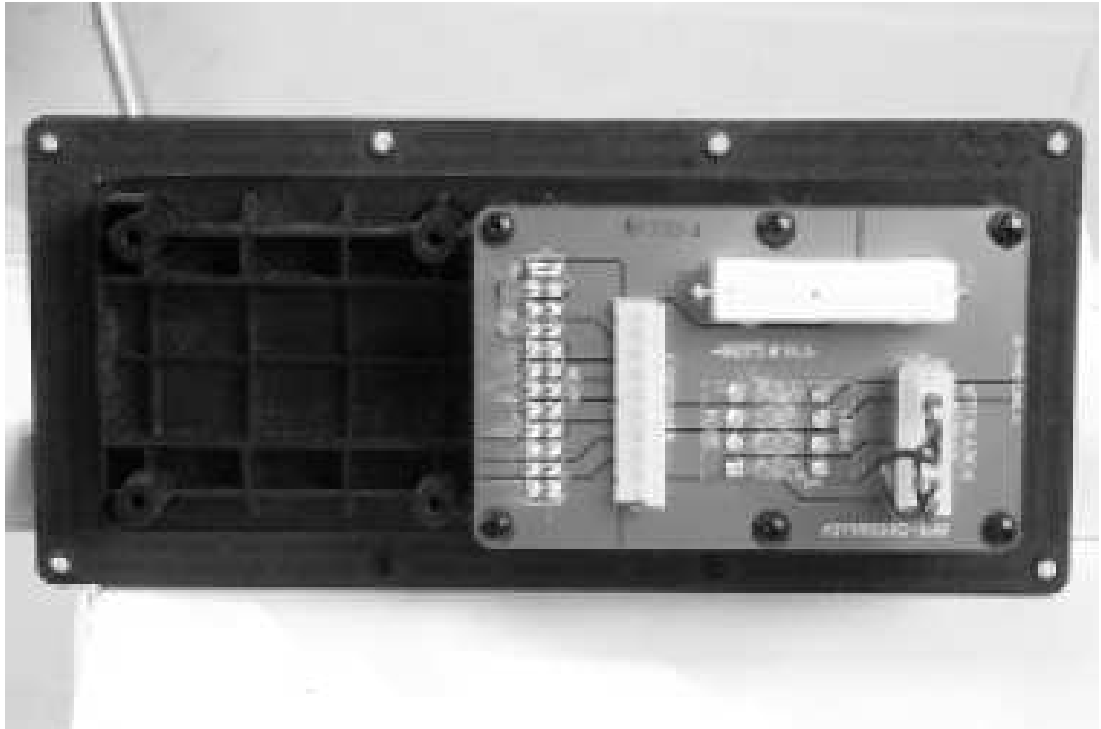

**Figure 6.4:** EVA input panel removed, showing the green PC board and the four bosses to which the optional EVA-AM attenuation module is attached

2. Unplug and discard the 7-pin jumper-wire connector.  
The cable connector of the attenuation module replaces this connector.
3. With the mounting straps on top, place the attenuation module into the pocket between the four bosses adjacent to the PC board and secure with the four screws (supplied).
4. Plug the cable of the attenuation module into the 7-position header on the PC board.

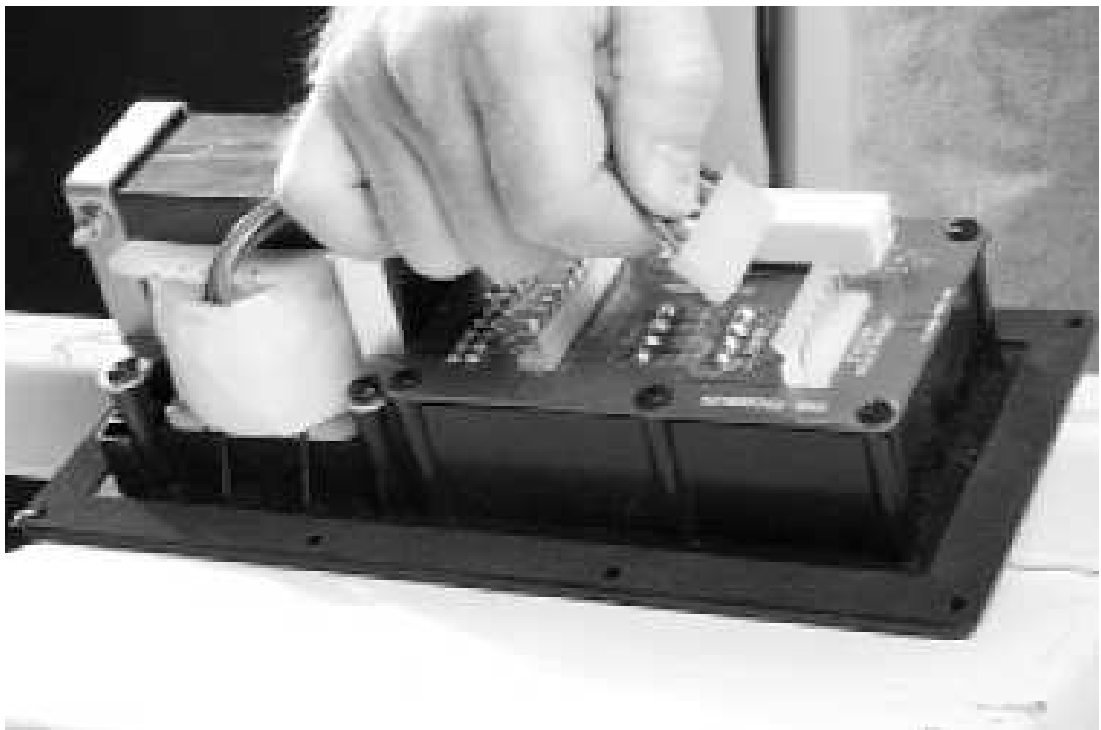

**Figure 6.5:** EVA input panel with EVA-AM installed showing connector plug-in

5. Apply the supplied label to the input panel around the input connectors. For more information on completing this step, refer to [EVA-AM Installation Instructions](#).
6. Reinstall the input panel assembly.
7. Connect a short piece of wire (supplied) from the “SELECT” terminal to the terminal marked -3, -6 or -9 dB, as determined by PREVIEW Loudspeaker Software.

## 7 Rigging system

### 7.1 Overview of the flying system

The external rigging parts supplied with each EVA line-array module attach to internal metal parts running top-to-bottom in each module, so that a finished array places no stress on the wooden enclosure parts.

The rigging simplification inherent in the EVA modules is based on the final array being assembled in a fixed manner as a single rigid structure. When flown as a single vertical column with EVA full-range modules, EVA subwoofer modules must always be assembled at the top of the array with no splay between them.

The EVA full-range enclosures are vertically trapezoidal: taller at the front than at the back. One module is fastened to another bottom to top. The vertical aiming angle between the two modules is fixed by their vertical draft angles. The draft angle is 3° for the EVA-2082S/906 and EVA-2082S/126 long-throw modules and 10° for the EVA-2082S/920 and EVA-2082S/1220 short-throw modules, producing 6°, 13° or 20° between any two modules, depending on which modules are attached together.



#### Notice!

The specific selection of long- and short-throw modules and their arrangement depend on room geometry and trim height. Electro-Voice PREVIEW Loudspeaker Software available on [www.electrovoice.com](http://www.electrovoice.com) facilitates these choices.

Each EVA module attaches to the module below it with the supplied pair of side-mounted tie plates. After assembling the array, attach the cosmetic end caps, one for each side of each module, to the enclosure. The cosmetic end caps hide the structural tie plates and give a smooth, attractive array appearance.

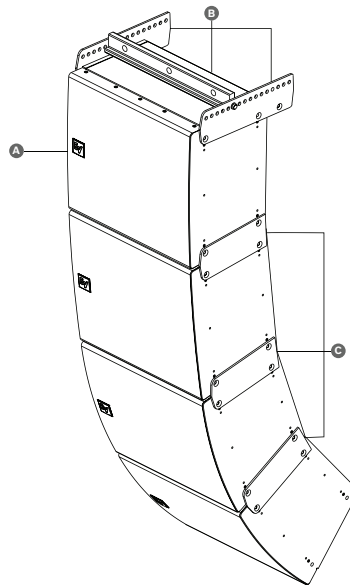
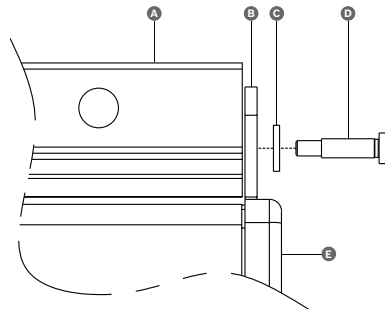

**Figure 7.1:** Typical EVA flying system (cosmetic end panels not shown)

A	EVA grid
B	EVA modules
C	Tie plates (2 supplied with each EVA module)

**To attach the tie plates:**

- ▶ Use the supplied M10 bolts.



**Figure 7.2:** Grid assembly detail

A	Spreader bar
B	Grid side arm
C	Nylon washer
D	M10 shoulder bolt
E	EVA module

**To assemble the grid:**

1. Attach the spreader bar with the supplied M10 shoulder bolts and nylon washers.
2. Attach the grid side arms with the M10 bolts supplied.

The majority of EVA applications come with full-range arrays of three or four modules. It is possible to suspend up to eight EVA-2082S and/or EVA-1151D (discontinued) modules together, with up to a combined maximum loudspeaker column weight of 720 lb (327 kg). When using EVA-2151D subwoofers, the combined maximum loudspeaker column weight is 840 lb (381 kg), or five EVA-2082S modules under two EVA-2151D modules. Subwoofers are installed at the top of the array.

## 7.2 Deciding which grid configuration to use with an array

### 7.2.1 Standard grid with or without second spreader bar

The EVA-SG2 standard grid is appropriate for the majority of applications covered by a three- to four-module full-range array.

**EVA-SG2 parts included**

Quantity	Component
1	Spreader bar
2	Side arm
2	Shoulder bolt
2	Nylon washer

The spreader bar and the two side arms assemble into a grid using the two shoulder bolts and nylon washers.

The spreader bar has three 0.813-inch (20.6 mm) holes through it, one near each end and one in the center. Chain hoist(s) or other device(s) used to lift the array into position attach to these holes.

The two end points provide horizontal stability for the array. The center point alone will probably require a tie-off to stabilize the horizontal position of the array.

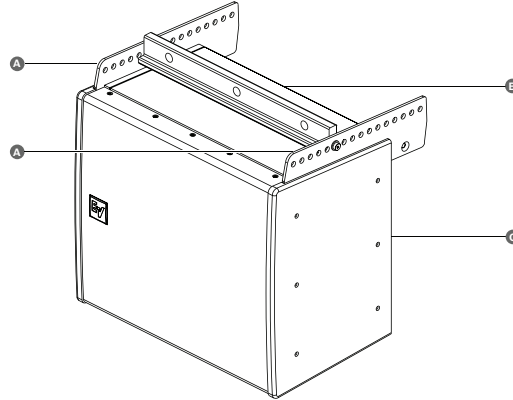

**Figure 7.3:** EVA-SG2 grid

A	Standard (EVA-SG2) side arm
B	Spreader bar
C	EVA module (not included with grid)

When using the standard grid with its single spreader bar, the front-to-back attachment position of the spreader bar determines the down angle of the array. This information is provided by Electro-Voice PREVIEW Loudspeaker Software, a function of the array makeup and desired vertical aiming.



**Notice!**

Use the EVA-EG2 extended grid for arrays larger than four EVA modules or for three- to four-box arrays that require more down angle than what is available with a standard grid. Refer to *Extended grid with or without second spreader bar, page 25.*

When two front-to-back pickup points are required, use the second spreader bar, EVA-GXB (sold separately).

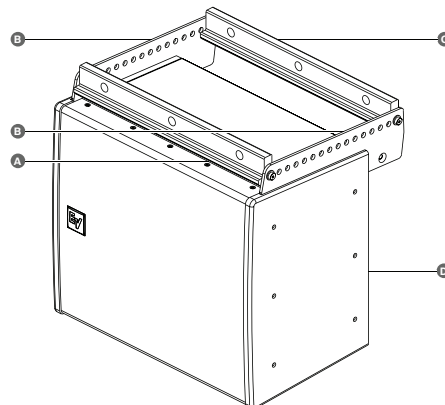

**Figure 7.4:** EVA-SG2 standard grid with optional EVA-GXB spreader bar



A	Spreader bar	B	Standard (EVA-SG2) side arm
C	Second (EVA-GXB) spreader bar (sold separately)	D	EVA module (not included with grid)

When using two spreader bars:

1. Attach one spreader bar to the extreme front hole positions in the side arms.
2. Attach the second spreader bar to the extreme rear position.  
This gives the most control over the vertical aiming of the array.



**Notice!**

Electro-Voice recommends EVA-EG2 extended grid when using front-to-back pickup points. The need to maintain sufficient load on the front spreader bar in order to maintain rigging tension diminishes the amount of down angle available with a standard grid.

**7.2.2**

**Extended grid with or without second spreader bar**

The EVA-EG2 extended grid is appropriate for arrays taller than four modules and three- to four-module arrays that require more down angle than what is available with a standard grid. The side arms of the EVA-EG2 are 11 inches longer to the rear.

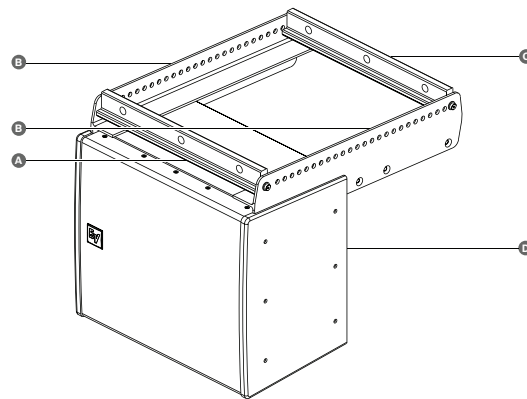

**Figure 7.5:** EVA-EG2 extended grid (shown with optional EVA-GXB spreader bar)

A	Spreader bar	B	Extended (EVA-EG2) side arm
C	Second (EVA-GXB) spreader bar (sold separately)	D	EVA module (not included with grid)

**7.2.3**

**Coupler grid with or without second spreader bar**

The EVA-CG coupler grid (discontinued) is used to fly up to three EVA-1151D subwoofer modules (discontinued) in an array behind up to five EVA-2082S full-range modules. It is an ideal solution when flying subwoofers with limited trim height.

The included spreader bar allows for:

- Single-point suspension.
- Two-point side-by-side suspension.

The included spreader bar with the addition of an optional second EVA-GXB spreader bar allows for:

- Two-point front-to-back suspension.

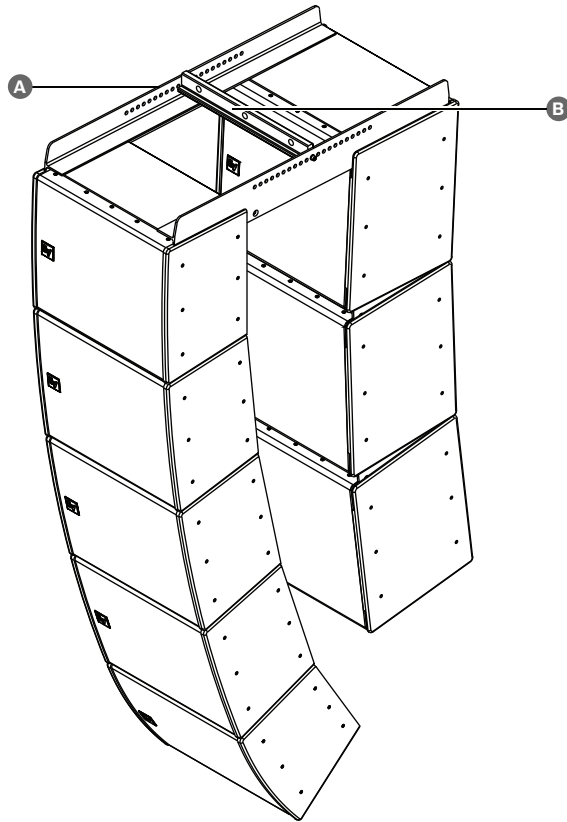

**Figure 7.6:** EVA-CG coupler grid arraying EVA-1151Ds (discontinued) behind EVA-2082Ss

A	EVA-CG coupler grid	B	EVA-GXB spreader bar
---	---------------------	---	----------------------

## 7.2.4

### Use of two standard grids

A configuration with two standard grids achieves extreme down angles, as seen in a distributed arena system.

When using two EVA-SG2 standard grids with an EVA array:

1. Attach one grid to the upper module.
2. Attach the other grid to the lower module.

This grid acts as a pull-up grid.

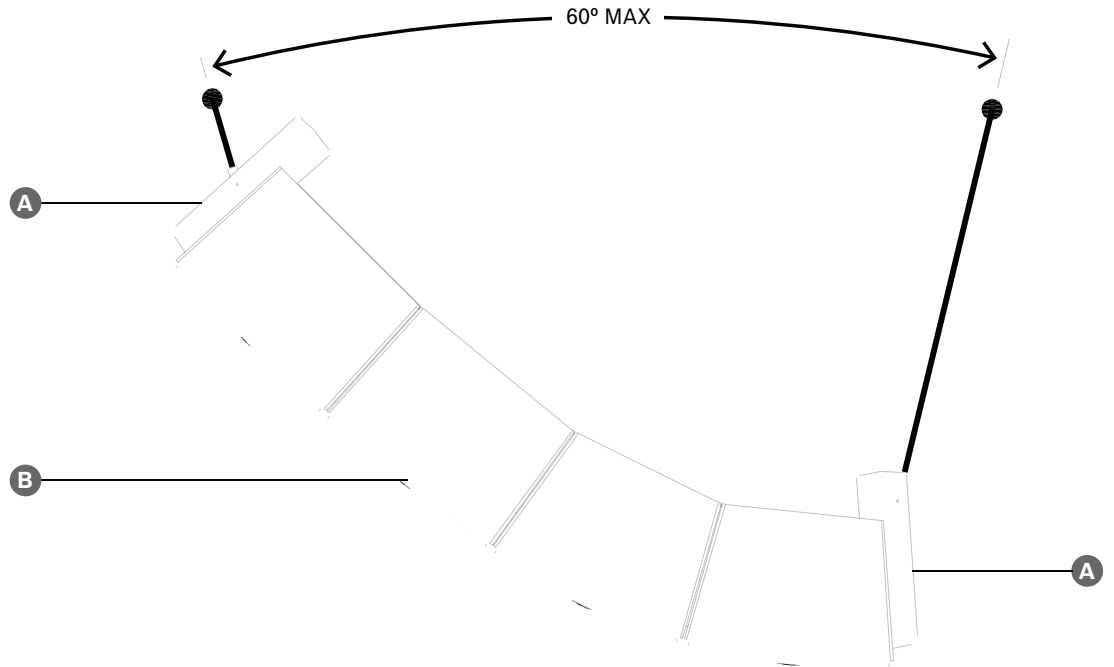

**Figure 7.7:** Use of two EVA-SG2 standard grids

A	EVA-SG2 standard grid	B	EVA module(s)
---	-----------------------	---	---------------



**Notice!**

When using two grids, the angle between the suspension lines must never exceed 60°. Do not use EVA-CG (discontinued), EVA-EG or EVA-EG2 grids in this application.

For overall down angles of about 45° or greater:

- ▶ Use the third-to-last hole of each grid.

For overall down angles of less than about 45°:

1. Use the third-to-last hole on the bottom grid.
2. Use any hole forward of third-to-last on the top grid.

**7.2.5**

**EVA-1151D tie plates**

Every EVA-1151D module (discontinued) includes tie plates.

**Features**

- Assembly of multiple EVA-1151D modules (discontinued) in a vertical column at either 0° or 5° of splay between modules.
- Provision of attachment points for suspending EVA-2082S modules underneath.
- Installation of an optional EVA-GXB spreader bar at the top of an EVA-1151D module (discontinued) by inverting the tie plates.

An EVA-GXB spreader bar at the top of an EVA-1151D module (discontinued) serves as a rudimentary flying grid for a stand-alone subwoofer hang, if only minimal down angle is required.

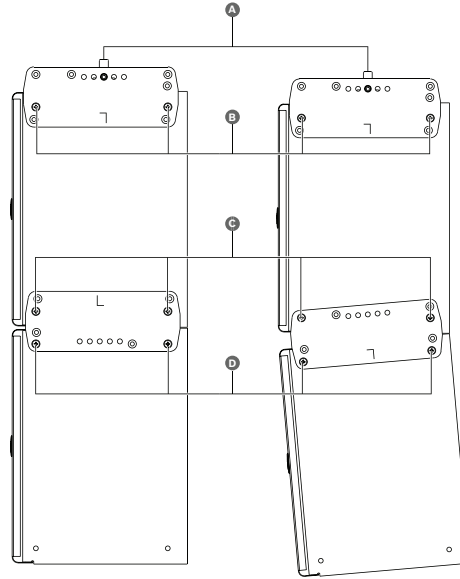

**Figure 7.8:** EVA-1151D to EVA-1151D array, 0° and 5° splay between enclosures

A	Holes to attach EVA-GXB spreader bar	B	Holes to attach to top of upper EVA-1151D
C	Holes to attach upper EVA-1151D	D	Holes to attach lower EVA-1151D

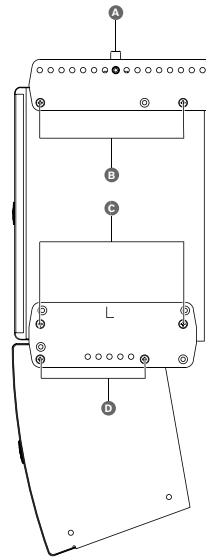

**Figure 7.9:** EVA-1151D to EVA-2082 array, 0° splay between enclosures

A	Holes to attach EVA-GXB spreader bar	B	Holes to attach to top of upper EVA-1151D
C	Holes to attach EVA-1151D	D	Holes to attach EVA-2082



**Notice!**

It is possible to use EVA-1151D tie plates as a suspension grid only with an EVA-GXB spreader bar (sold separately).

### 7.3 Assembling and flying an array

Each end of an EVA module has a pair of upper and lower connection points. These connections points accept the supplied M10 flathead bolts and are used to:

- Attach the side arms of an EVA grid to the top of the upper array module.
- Attach the tie plates supplied with each module, so that the modules are attached to each other.
- Attach an EVA-SG2 grid to the bottom module for use as a pull-up point.

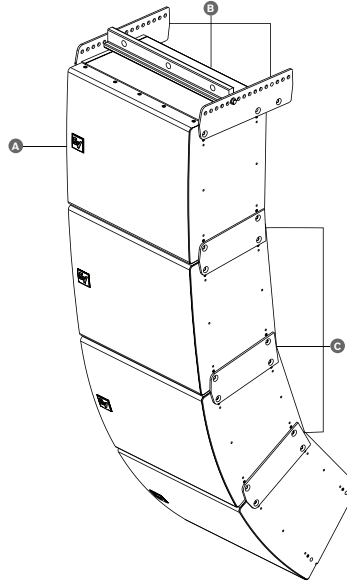

**Figure 7.10:** Typical EVA flying system (cosmetic end panels not shown)

A	EVA grid
B	EVA modules
C	Tie plates (2 supplied with each EVA module)

**To assemble the EVA grid:**

1. Using the supplied M10 bolts, attach the two side arms of the grid to the upper array module and tighten securely.
2. Attach a single spreader bar to the side-arm holes shown in PREVIEW Loudspeaker Software.  
These holes provide the required aiming angle of the array.



**Notice!**

When using two spreader bars, attach the spreader bars to the extreme front and back positions on the side arms. This provides maximum control over the vertical aiming angle of the array.

3. Attach a chain hoist(s) or other lifting device(s) to the assembled grid and the upper EVA module.

**To assemble the EVA array:**

1. Lift the assembly to the point where the second EVA module is slipped under the suspended partial array.

2. Using four M10 flathead screws (supplied), attach a tie plate (flat end to the rear) to each end of the suspended module. Do not fully tighten the screws.
3. Move the second module into place under the suspended module between the tie plates.
4. Align the holes in the tie plates with the corresponding holes in the lower module and assemble the module to the one above with four M10 flathead screws (supplied).
5. Fully tighten all eight M10 screws.
6. Connect the input terminals of the uppermost full-range module in parallel with the EVA full-range modules below it.

**Notice!**

Subwoofer modules require a dedicated amplifier channel and may need individual wiring according to their combined impedance and the drive capabilities of the amplifier.

7. Repeat steps 1 through 6 to attach additional EVA modules.

**Warning!**

To prevent audible air leaks, install a pair of M10 screws per end panel of the last module where the tie plate would attach.

**To complete the EVA array:**

1. Using the supplied M5 screws, attach the cosmetic end panels.
2. Tighten the screws by hand or use a power drill with a moderate torque setting.  
Do not overtighten. Overtightening drives the screws through the wood of the end panels.

**Notice!**

An array is typically fed from the top down. Wire each module to the module above (except for subwoofer modules), and set and verify the shading selector position per PREVIEW Loudspeaker Software.

3. If needed, install attenuation modules.

**Warning!**

Shading and/or attenuation in the wrong place seriously detracts from the performance of the completed array.

4. Hoist the completed array into position and secure it in the final way intended.

## 8 Rigging-strength ratings and safety factors

### 8.1 Working-load limit and safety factor definitions

The structural ratings for all of the EVA rigging components and complete loudspeaker systems are based on test results in which parts were stressed to failure. Manufacturers typically present the structural-strength ratings of mechanical components or systems as either the working-load limit (WLL) or the ultimate-break strength. Electro-Voice chooses to present the structural-load ratings of the EVA loudspeaker systems as the working-load limit. The working-load limit rating represents the maximum load that should ever be applied to a mechanical component or system.

**Warning!**

Never apply a load that exceeds the working-load limits of any of the rigging components or complete loudspeaker systems described in this manual.

The working-load limits for the EVA rigging components and complete loudspeaker systems described in this manual are based on a minimum 8:1 safety factor. The safety factor is defined as the ratio of the ultimate-break strength divided by the working-load limit, where the ultimate-break strength represents the force at which a part will structurally fail. For example, if a part has a working-load limit of 1,000 lb (454 kg), it would not structurally fail until a force of at least 8,000 lb (3,629 kg) is applied, based on an 8:1 safety factor. However, the user should never apply a load to that part that exceeds 1,000 lb (454 kg). The safety factor provides a margin of safety above the working-load limit to accommodate normal dynamic loading and normal wear.

**Caution!**

Never exceed the working-load limits defined by the manufacturer of any rigging component. Electro-Voice bases the working-load limits of its EVA products on a minimum of an 8:1 safety factor. Other manufacturers of rigging components may base their working-load limits on safety factors other than 8:1. For example, 5:1 safety factors are fairly common amongst rigging manufacturers because many regulatory agencies call for a minimum safety factor of 5:1.

**Caution!**

If local regulations only require a safety factor of 5:1, Electro-Voice insists that the working-load limits of the EVA rigging never be exceeded and that an 8:1 safety factor be maintained for the EVA loudspeakers.

**Caution!**

Some local regulations may require safety factors higher than 8:1. In that circumstance, Electro-Voice insists that the user maintains the higher safety factor as required by the local regulations throughout the entire EVA installation. It is the responsibility of the user to make sure that any EVA installation meets all applicable local, state or federal safety regulations.

### 8.2 Structural-rating overview

Designing a safe structural array is ordinarily a very complex process best left to experienced professionals.

Two independent strength considerations give a complete description of the overall **structural capabilities of any loudspeaker system:**

1. The strength of each individual enclosure rigging point, which is the combined strength of the internal rigging straps, external tie plates, bolts and enclosure.
2. The total strength of the overall array, which is a function of the combined forces from all of the rigging points acting on the rigging components and the array as a whole.

Two independent strength considerations give a complete description of the overall **structural capabilities of the grid**:

1. The strength of each individual grid rigging point, which is the combined strength of the bolts, grid side arms and spreader bars.
2. The total strength of the overall grid, which is a function of the combined forces from all of the rigging points acting on the rigging components and the grid as a whole.

In any system, the forces acting on each loudspeaker (on each individual rigging point and on the overall enclosure) and the forces acting on each rigging accessory (grids and spreader bars) will vary with each array configuration. Determining those forces throughout an array requires complex mathematical calculations.

For a set of simplified structural-rating guidelines, refer to *Structural rating charts, page 34*.

These guidelines combine destructive testing and computer modeling, enabling a rigger to determine immediately on site whether an array is safe.

To make EVA systems both safe and easy to use, Electro-Voice engineers have chosen to treat EVA arrays as a single unified structure rather than individual components. All the complex factors have been taken into account to design a rigging system strong enough to maintain a minimum 8:1 safety factor up to a maximum suspended column weight of 720 lb (327 kg) at any elevation (tilt) angle available on the EVA-SG2 or EVA-EG2 grid with any combination of EVA-1151D (discontinued) and/or EVA-2082S modules. The maximum suspended column weight for the EVA-CG coupler grid (discontinued) is 760 lb (345 kg). The EVA-2151D may only be flown from the EVA-EG2 grid. The maximum single-point suspended column weight using EVA-2151D subwoofers is 840 lb (381 kg). Refer to *Special rules when flying EVA-2151D subwoofer modules, page 32*.

#### Refer to

- *Structural rating charts, page 34*
- *Special rules when flying EVA-2151D subwoofer modules, page 32*

## 8.3

### Special rules when flying EVA-2151D subwoofer modules

EVA-2151D subwoofers may only be flown from an EVA-EG2 grid. Because the EVA-2151D modules have six rigging points instead of four, the maximum load ratings are higher, but require special conditions to achieve.

When flying EVA-2082S full-range modules below EVA-2151D subwoofer modules:

- Use up to two EVA-2151D modules and up to five EVA-2082S modules.
- Use a bottom pull-up point as long as the maximum angle on the grid does not exceed 45° and the maximum pull angle between suspension lines does not exceed 60°.
- Do not exceed the maximum single-point column weight of 840 lb (381 kg) when using EVA-2151D subwoofers.

When flying EVA-2151D subwoofer modules as a stand-alone subwoofer array using the center attachment point on the spreader bar(s):

- Use up to four EVA-2151D modules, even if using two spreader bars.



- For extreme down angles, attach a second EVA-EG2 grid at the bottom of the array for use as a pull-up point, as long as the maximum pull angle between suspension lines does not exceed 60°.

When flying five or more EVA-2151D modules:

- Use only the two outermost attachment holes on the spreader bar.

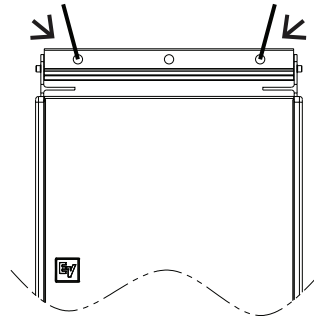

- If using two spreader bars, use the two outermost attachment holes on each bar.
- You are allowed to use a maximum vertical column of eight modules, if the column is kept perpendicular to the ground.
- The maximum suspended column weight in a stand-alone subwoofer array with 0° of inclination (tilt) angle using both outer attachment points on the spreader bar is 1,470 lb (667 kg).



**Warning!**

Any array with more than four EVA-2151Ds must use the two outermost attachment holes on the spreader bar.



**Warning!**

Never attempt to suspend EVA systems overhead by any other method than the use of EVA-SG2, EVA-EG2 or EVA-CG (discontinued) grids and spreader bars, as outlined in this manual. EVA-1151D modules (discontinued) may be suspended from inverted EVA-1151D tie plates only with an EVA-GXB spreader bar (sold separately).

## 8.4

### Simplified structural-rating guidelines

The simplified structural-rating guidelines for EVA loudspeakers were determined based on:

1. Vertical elevation possible with EVA-SG2, EVA-EG2 and EVA-CG (discontinued) grids.
2. Total weight of all enclosures in the array plus accessories, cabling and rigging.
3. Angled forces acting on rigging components and enclosures.

When applying the structural rating guidelines to any EVA loudspeaker system suspended overhead:

1. Never exceed 720 lb (327 kg) total column weight of suspended EVA-1151D (discontinued) and EVA-2082S loudspeakers, accessories and cabling (typically any combination of eight EVA-2082S and/or EVA-1151D modules).
2. When flown in the same column with full-range modules from an EVA-SG2 or EVA-EG2 grid, subwoofers must always be at the top of the array with no splay between modules.
3. If using a second grid at the bottom of the array, the angle between the suspension lines must never exceed 60°. Do not use EVA-CG (discontinued), EVA-EG or EVA-EG2 grids in this application.

4. The suspended column must be perpendicular (plumb) to within  $\pm 5$  degrees.
5. If suspending a spreader bar or grid from two points, the angle between those two suspension lines must not exceed  $60^\circ$  (maximum  $30^\circ$  from plumb each).
6. Never exceed 760 lb (345 kg) total column weight when using the EVA-CG coupler grid (discontinued). When flying EVA-1151D modules (discontinued) behind EVA-2082S full-range modules on the EVA-CG coupler grid, the maximum number of EVA-2082S full-range modules at the front of the grid is five and the maximum number of EVA-1151D subwoofer modules (discontinued) at the rear of the grid is three. A bottom pull-up is not allowed when using the EVA-CG. Flying a single column from the EVA-CG is not allowed.

Refer to *Structural rating charts*, page 34.

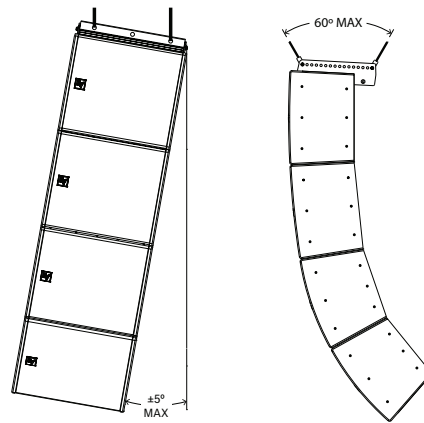

**Figure 8.1:** Left: side-to-side simplified structural-rating guidelines for EVA arrays (angle shown exaggerated for illustration purposes). Right: front-to-back angular pull structural-rating guidelines for EVA spreader bars

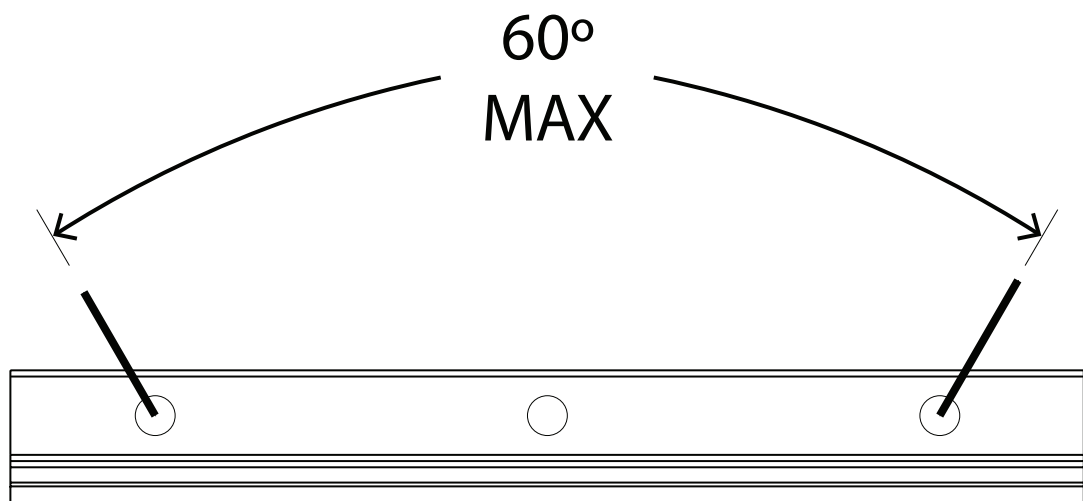

**Figure 8.2:** Side-to-side angular pull structural-rating guidelines for EVA spreader bars

## 8.5

### Structural rating charts



#### Warning!

Use only the listed combinations.

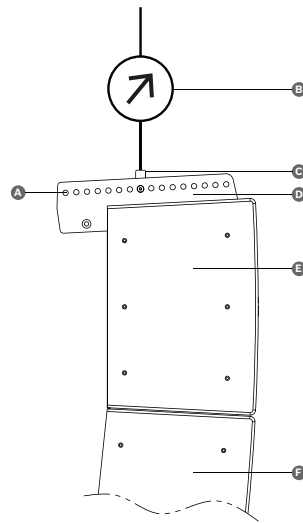

A	Pin holes	B	Maximum permissible column weight
C	Spreader bar	D	Grid
E	Position 1	F	Position 2

Position	720 lb (327 kg) maximum column weight, any pin-hole, any angle						
1 (top)	2082S	2082S	2082S	2082S	2082S	2082S	2082S
2	2082S	2082S	2082S	2082S	2082S	2082S	2082S
3		2082S	2082S	2082S	2082S	2082S	2082S
4			2082S	2082S	2082S	2082S	2082S
5				2082S	2082S	2082S	2082S
6					2082S	2082S	2082S
7						2082S	2082S
8							2082S

**Table 8.7:** 2080S modules on EVA-SG2 grid

Position	720 lb (327 kg) maximum column weight, any pin-hole, any angle Subs must be at the top of the array with NO SPLAY between them									
	1 (top)	1151D	1151D	1151D	1151D	1151D	1151D	1151D	1151D	1151D
2	2082S	2082S	1151D	1151D	1151D	1151D	1151D	1151D	1151D	1151D
3	2082S	2082S	2082S	2082S	2082S	1151D	2082S	1151D	1151D	1151D
4		2082S	2082S	2082S	2082S	2082S	2082S	2082S	2082S	1151D
5				2082S	2082S	2082S	2082S	2082S	2082S	2082S
6					2082S	2082S	2082S	2082S	2082S	2082S
7							2082S	2082S	2082S	2082S
8									2082S	2082S

**Table 8.8:** 1151D modules over 2082S modules on EVA-SG2 grid

Position	720 lb (327 kg) maximum column weight, any pin-hole, any angle Subs must be at the top of the array with NO SPLAY between them									
	1 (top)	1151D	1151D	1151D	1151D	1151D	1151D	1151D	1151D	1151D
2	2082S	2082S	1151D	1151D	1151D	1151D	1151D	1151D	1151D	1151D
3	2082S	2082S	2082S	2082S	2082S	1151D	2082S	1151D	1151D	1151D
4		2082S	2082S	2082S	2082S	2082S	2082S	2082S	2082S	1151D
5				2082S	2082S	2082S	2082S	2082S	2082S	2082S
6					2082S	2082S	2082S	2082S	2082S	2082S
7							2082S	2082S	2082S	2082S
8									2082S	2082S

**Table 8.9:** 1151D modules over 2082S modules on EVA-EG2 grid

Position	840 lb (381 kg) maximum column weight, any pin-hole Angle not to exceed 45° down with bottom pull-up						
	1 (top)	2151D	2151D	2151D	2151D	2151D	2151D
2	2082S	2082S	2082S	2151D	2082S	2151D	2151D
3	2082S	2082S	2082S	2082S	2082S	2082S	2082S
4		2082S	2082S	2082S	2082S	2082S	2082S
5			2082S	2082S	2082S	2082S	2082S
6					2082S	2082S	2082S
7							2082S

8										N/A
---	--	--	--	--	--	--	--	--	--	-----

**Table 8.10:** 2151D modules over 2082S modules on EVA-EG2 grid

Position	760 lb (345 kg) maximum combined column weight, any pin-hole No bottom pull-up allowed									
	Front	Rear	Front	Rear	Front	Rear	Front	Rear	Front	Rear
1 (top)	2082S	1151D	2082S	1151D	2082S	1151D	2082S	1151D	2082S	1151D
2	2082S		2082S	1151D	2082S		2082S	1151D	2082S	1151D
3					2082S		2082S		2082S	
4									2082S	
5										

**Table 8.11:** 1151 modules behind 2082S modules on EVA-CG grid (discontinued)

Position	760 lb (345 kg) maximum combined column weight, any pin-hole No bottom pull-up allowed					
	Front	Rear	Front	Rear	Front	Rear
1 (top)	2082S	1151D	2082S	1151D	2082S	1151D
2	2082S	1151D	2082S	1151D	2082S	1151D
3	2082S	1151D	2082S		2082S	1151D
4	2082S		2082S		2082S	
5			2082S		2082S	

**Table 8.12:** 1151 modules behind 2082S modules on EVA-CG grid (discontinued)

Position	720 lb (327 kg) maximum column weight, any pin-hole, any angle							
1 (top)	1151D	1151D	1151D	1151D	1151D	1151D	1151D	1151D
2		1151D	1151D	1151D	1151D	1151D	1151D	1151D
3			1151D	1151D	1151D	1151D	1151D	1151D
4				1151D	1151D	1151D	1151D	1151D
5					1151D	1151D	1151D	1151D
6						1151D	1151D	1151D
7							1151D	1151D
8								1151D

**Table 8.13:** Stand-alone subwoofer array of 1151D modules on EVA-SG2 grid

Position	720 lb (327 kg) maximum column weight, any pin-hole, any angle							
1 (top)	1151D	1151D	1151D	1151D	1151D	1151D	1151D	1151D
2		1151D	1151D	1151D	1151D	1151D	1151D	1151D
3			1151D	1151D	1151D	1151D	1151D	1151D
4				1151D	1151D	1151D	1151D	1151D
5					1151D	1151D	1151D	1151D
6						1151D	1151D	1151D
7							1151D	1151D
8								1151D

**Table 8.14:** Stand-alone subwoofer array of 1151D modules on EVA-EG2 grid

Position	840 lb (381 kg) maximum column weight, any pin-hole, any angle			
1 (top)	2151D	2151D	2151D	2151D
2		2151D	2151D	2151D
3			2151D	2151D
4				2151D
5				N/A
6				N/A
7				N/A
8				N/A

**Table 8.15:** Stand-alone subwoofer array of 2151D modules on EVA-EG2 grid

Position	1470 lb (667 kg) maximum column weight at 0° only Must use both outer suspension points on spreader bar(s)			
1 (top)	2151D	2151D	2151D	2151D
2	2151D	2151D	2151D	2151D
3	2151D	2151D	2151D	2151D
4	2151D	2151D	2151D	2151D
5	2151D	2151D	2151D	2151D
6		2151D	2151D	2151D
7			2151D	2151D
8				2151D

**Table 8.16:** Stand-alone subwoofer array of 2151D modules on EVA-EG2 grid, no tilt

## 8.6 Structural-analysis procedures

Electro-Voice maintains a structural pull-test facility in Burnsville, Minnesota USA, which includes load cells with digital-electronic display and recording. The load cells are calibrated annually by an independent laboratory to a standard traceable to the United States National Bureau of Standards. This pull-test facility is capable of pulling to destruction both individual rigging components and complete loudspeaker systems.

Electro-Voice utilizes state-of-the-art computer-modeling programs for structural analysis throughout the development of loudspeaker systems. The computer modeling enables the complex forces in the rigging components and enclosures to be analyzed for loudspeakers assembled into arrays in both static and dynamic conditions.

Structural testing and computer modeling were used throughout the engineering development of all EVA individual rigging components and complete loudspeaker systems described in this manual. Testing and modeling involving both anticipated use and anticipated misuse were performed as part of the analysis. Engineering prototypes were stressed to failure and designs were revised based on those test results. Production systems and components were stressed to failure for verification of the final designs.

## 9 Rigging inspection and precautions

**Loudspeaker systems:** Prior to each use, inspect the enclosures for any cracks, deformations or missing or damaged components that could reduce enclosure strength. Inspect the tie plates between enclosures for cracks, corrosion or other deformations that could reduce their strength and integrity. Make sure there are no missing screws and that all M10 rigging bolts are securely tightened. Replace all hardware that is bent or showing signs of more than cosmetic surface corrosion immediately.

**Grids:** Prior to each use, inspect the grid side bars and spreader bars for any cracks, corrosion, missing or damaged parts or any other deformation that could reduce their strength and integrity. Make sure there are no missing screws and that all M10 rigging bolts are securely tightened. Replace all hardware that is bent or showing signs of more than cosmetic surface corrosion immediately.

**Lifting hoists:** Prior to each use, inspect the lifting hoist(s) and associated hardware (including motor(s), if applicable) for any cracks, deformation, broken welds, corrosion, missing or damaged components that could reduce the hoist strength. Replace any damaged hoists. Never exceed the limitations or maximum recommended load specified by the hoist manufacturer. Always follow manufacturers' recommendations for operation, inspection, and certification. Always raise and lower the load slowly and evenly, avoiding any rapid changes in speed or shifting loads that could result in a sudden jolt to the suspended system or the structure from which it is suspended.

**Building, tower or scaffold supports:** Prior to each use, the strength and load-bearing capabilities of the building, tower or scaffold structural supports should be evaluated and certified by a professional engineer as being adequate for supporting the intended rigging system (including the loudspeakers, grids, chain hoists, and all associated hardware). Prior to each use, inspect the building, tower or scaffold structural supports for any cracks, deformation, broken welds, corrosion, missing or damaged components that could reduce the structural strength. Damaged structural supports should be replaced or repaired and recertified by a professional engineer. Never exceed the limitations or maximum recommended load for the supports.

**Miscellaneous mechanical components:** Prior to each use, inspect all mechanical components (chain, wire ropes, slings, shackles, hooks, fittings, ratchet straps, etc.) for any cracks, deformation, broken welds, slipping crimps, fraying, abrasion, knots, corrosion, chemical damage, loose screws, missing or damaged components that could reduce the maximum strength specified by the component manufacturer. Replace any damaged mechanical components immediately. Never exceed the limitations or maximum recommended load for the mechanical components.



## 10

## References

### 10.1

#### Rigging (printed)

- [1] W.E. Rossnagel, L.R. Higgins & J.A. MacDonald, Handbook of Rigging for Construction and Industrial Operations, McGraw-Hill Book Company, New York, NY, USA (1988).
- [2] H. Donovan, Entertainment Rigging, <http://www.riggingbooksandprograms.com>, Rigging Seminars, Seattle, WA, USA (2002)
- [3] J.O. Glerum, Stage Rigging Handbook, Southern Illinois University Press, Carbondale, IL, USA (1987).
- [4] P. Carter, Backstage Handbook, Broadway Press, New York, NY, USA (1988).
- [5] ATM Fly-Ware™, Riggermeister Production Rigging Guide, ATM Fly-Ware™, Carson, CA, USA (1995).
- [6] Wire Rope Technical Board, Wire Rope Users Manual, American Iron and Steel Institute, Stevensville, MD, USA (1985).
- [7] Broderick & Bascom Rope Company, Rigger's Handbook, Sedalia, MO, USA (1993).
- [8] MacWhite Wire Rope Company, Catalog of Tables, Data and Helpful Information, Kenosha, WI, USA (1991).
- [9] Acco Chain & Lifting Division, Chain Sling User's Manual, Acco Corporation, York, PA, USA (1992).
- [10] Newberry, W.G., Handbook for Riggers, Newberry Investments Company, Calgary, Alberta, Canada (1989).

### 10.2

#### Mechanical engineering (printed)

- [1] R.C. Hibbeler, Engineering Mechanics Statics & Dynamics, Pearson Prentice Hall, Upper Saddle River, NJ, USA (2005)
- [2] R.C. Hibbeler, Mechanics of Materials, Pearson Prentice Hall, Upper Saddle River, NJ, USA (2005)
- [3] J.L. Meriam & L.G. Kraige, Engineering Mechanics, Volume One - Statics, John Wiley & Sons, Inc., New York, NY, USA (1992).
- [4] J.L. Meriam & L.G. Kraige, Engineering Mechanics, Volume Two - Dynamics, John Wiley & Sons, Inc., New York, NY, USA (1992).
- [5] J.E. Shigley & C.R. Mischke, Mechanical Engineering Design, McGraw-Hill Book Company, New York, NY, USA (1989).

### 10.3

#### Rigging (websites)

- [1] <http://www.rigging.net>





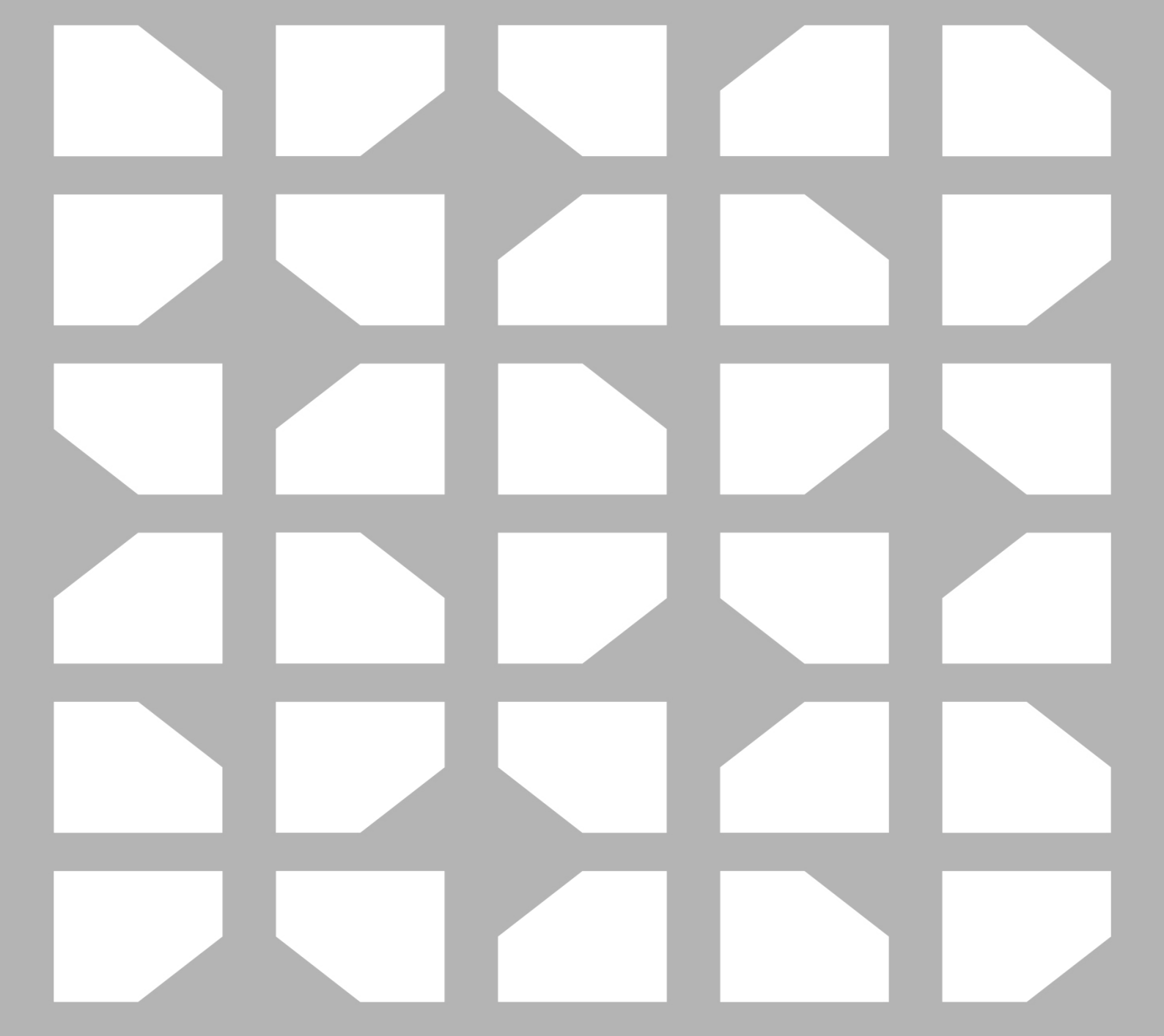

**Bosch Sicherheitssysteme GmbH** **Bosch Security Systems, LLC**

Robert-Bosch-Ring 5  
85630 Grasbrunn  
Germany

[www.boschsecurity.com](http://www.boschsecurity.com)

© Bosch Sicherheitssysteme  
GmbH, 2022

12000 Portland Avenue South  
Burnsville MN 55337  
USA

[www.electrovoice.com](http://www.electrovoice.com)

© Bosch Security Systems,  
LLC, 2022