

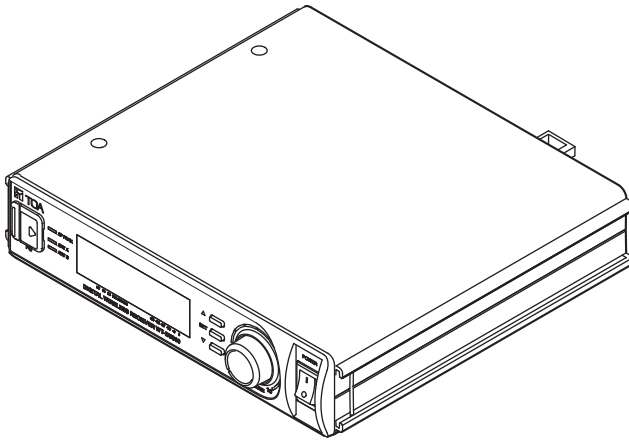

CE  
INSTRUCTION MANUAL

DIGITAL WIRELESS RECEIVER

WT-D5800



Thank you for purchasing TOA's Digital Wireless Receiver.  
Please carefully follow the instructions in this manual to ensure long, trouble-free use of your equipment.

## TABLE OF CONTENTS

<b>1. SAFETY PRECAUTIONS</b> .....	3
<b>2. GENERAL DESCRIPTION</b> .....	6
<b>3. FEATURES</b> .....	6
<b>4. HANDLING PRECAUTIONS</b> .....	6
<b>5. NOMENCLATURE AND FUNCTIONS</b> .....	7
Front .....	7
Rear .....	8
<b>6. RACK MOUNTING</b> .....	9
<b>7. CONNECTION EXAMPLES</b> .....	10
7.1. Example 1 .....	10
7.2. Example 2 .....	10
7.3. Contact Output Settings .....	11
<b>8. FUNCTION SETTINGS</b> .....	12
8.1. Placing the Unit in Setting Mode .....	12
8.2. Setting Items Displayed on the LCD Screen in Setting Mode .....	12
8.3. Function Settings .....	13
<b>9. OPERATION</b> .....	24
<b>10. HOW TO CHECK AND DEAL WITH INTERFERENCE</b> .....	25
<b>11. SPECIFICATIONS</b> .....	27
Accessories .....	27
Optional products .....	27

# 1. SAFETY PRECAUTIONS

- Before installation or use, be sure to carefully read all the instructions in this section for correct and safe operation.
- Be sure to follow all the precautionary instructions in this section, which contain important warnings and/or cautions regarding safety.
- After reading, keep this manual handy for future reference.



## WARNING

Indicates a potentially hazardous situation which, if mishandled, could result in death or serious personal injury.

### When Installing the Unit

- Do not expose the unit to rain or an environment where it may be splashed by water or other liquids, as doing so may result in fire or electric shock.
- Use the unit only with the voltage specified on the unit. Using a voltage higher than that which is specified may result in fire or electric shock.
- Do not cut, kink, otherwise damage nor modify the power supply cord. In addition, avoid using the power cord in close proximity to heaters, and never place heavy objects -- including the unit itself -- on the power cord, as doing so may result in fire or electric shock.
- Avoid installing or mounting the unit in unstable locations, such as on a rickety table or a slanted surface. Doing so may result in the unit falling down and causing personal injury and/or property damage.
- Since the unit is designed for indoor use, do not install it outdoors. If installed outdoors, the aging of parts causes the unit to fall off, resulting in personal injury. Also, when it gets wet with rain, there is a danger of electric shock.

### When the Unit is in Use

- Should the following irregularity be found during use, immediately switch off the

power, disconnect the power supply plug from the AC outlet and contact your nearest TOA dealer. Make no further attempt to operate the unit in this condition as this may cause fire or electric shock.

- If you detect smoke or a strange smell coming from the unit
- If water or any metallic object gets into the unit
- If the unit falls, or the unit case breaks
- If the power supply cord is damaged (exposure of the core, disconnection, etc.)
- If it is malfunctioning (no tone sounds)
- If it is malfunctioning (no LCD indication appears)
- To prevent a fire or electric shock, never open nor remove the unit case as there are high voltage components inside the unit. Refer all servicing to qualified service personnel.
- Do not place cups, bowls, or other containers of liquid or metallic objects on top of the unit. If they accidentally spill into the unit, this may cause a fire or electric shock.
- Do not insert nor drop metallic objects or flammable materials in the ventilation slots of the unit's cover, as this may result in fire or electric shock.
- Do not touch a power supply plug or antenna during thunder and lightning, as this may result in electric shock.
- To prevent the electromagnetic wave from badly influencing medical equipment, make sure to switch off the unit's power when placing it in close proximity to the medical equipment.

## **CAUTION**

Indicates a potentially hazardous situation which, if mishandled, could result in moderate or minor personal injury, and/or property damage.

### **When Installing the Unit**

- Never plug in nor remove the power supply plug with wet hands, as doing so may cause electric shock.
- When unplugging the power supply cord, be sure to grasp the power supply plug; never pull on the cord itself. Operating the unit with a damaged power supply cord may cause a fire or electric shock.
- When moving the unit, be sure to remove its power supply cord from the wall outlet. Moving the unit with the power cord connected to the outlet may cause damage to the power cord, resulting in fire or electric shock. When removing the power cord, be sure to hold its plug to pull.
- Avoid installing the unit in humid or dusty locations, in locations exposed to the direct sunlight, near the heaters, or in locations generating sooty smoke or steam as doing otherwise may result in fire or electric shock.
- Be sure to follow the instructions below when rack-mounting the unit. Failure to do so may cause a fire or personal injury.
  - Install the equipment rack on a stable, hard floor. Fix it with anchor bolts or take other arrangements to prevent it from falling down.
  - When connecting the unit's power cord to an AC outlet, use the AC outlet with current capacity allowable to the unit.

### **When the Unit is in Use**

- Make sure that the volume control is set to minimum position before power is switched

on. Loud noise produced at high volume when power is switched on can impair hearing.

- Do not operate the unit for an extended period of time with the sound distorting. Doing so may cause the connected speakers to heat, resulting in a fire.
- Use the dedicated AC adapter for the unit. Note that the use of other adapter may cause a fire.
- Contact your TOA dealer as to the cleaning. If dust is allowed to accumulate in the unit over a long period of time, a fire or damage to the unit may result.
- If dust accumulates on the power supply plug or in the wall AC outlet, a fire may result. Clean it periodically. In addition, insert the plug in the wall outlet securely.
- Switch off the power, and unplug the power supply plug from the AC outlet for safety purposes when cleaning or leaving the unit unused for 10 days or more. Doing otherwise may cause a fire or electric shock.
- Any modifications made to this device that are not approved by TOA Corporation may void the authority granted to the user to operate this equipment.

**CAUTION TO USER:**

Changes or modifications not expressly approved by the party responsible for compliance could void the user's authority to operate the equipment.

**IMPORTANT NOTE:** To comply with the FCC RF exposure compliance requirements, no change to the antenna or the device is permitted. Any change to the antenna or the device could result in the device exceeding the RF exposure requirements and void user's authority to operate the device.

**License requirement**

This device complies with Part 15 of the FCC Rules.

This device complies with Industry Canada licence-exempt RSS standard(s). Operation is subject to the following two conditions;

(1) This device may not cause harmful interference, and (2) this device must accept any interference received, including interference that may cause undesired operation.

Le présent appareil est conforme aux CNR d'Industrie Canada applicables aux appareils radio exempts de licence. L'exploitation est autorisée aux deux conditions suivantes : (1) l'appareil ne doit pas produire de brouillage, et (2) l'utilisateur de l'appareil doit accepter tout brouillage radioélectrique subi, même si le brouillage est susceptible d'en compromettre le fonctionnement.

## 2. GENERAL DESCRIPTION

The WT-D5800 is a digital wireless receiver that employs the PLL synthesizer communication method.

Use this receiver in combination with TOA's WM-D5200 or WM-D5300 digital wireless microphone.

## 3. FEATURES

- The digital true diversity method minimizes radio interference and noise, ensuring stable radio wave reception.
- TOA's unique digital audio signal processing technology eliminates sound quality deterioration common to analog systems.
- Digital transmission and encryption settings reduce the chance of transmitted information being leaked outside the area of use.
- Systems using the same channel can be installed closer to each other than possible with analog systems.
- Battery data is transmitted from the wireless microphone to the receiver, allowing the receiver to provide a visual readout of the microphone's remaining battery charge.
- Idle channels can be displayed by way of channel scanning.
- A contact output terminal is provided for control of external equipment.
- Feedback suppressor automatically suppresses acoustic feedback.
- Connecting the unit to a PC allows the reception status to be monitored using the WT-D5800 Maintenance Software\*, which is useful for installation and maintenance.

\* Download from the TOA website (<https://www.toa-products.com/international/>).

## 4. HANDLING PRECAUTIONS

- Make sure that the power switch is switched OFF after use.
- When mounting in an equipment rack, select the position which does not expose the unit to high temperature.
- When installing, keep the unit as far away as possible from fluorescent lamps, digital equipment, personal computers, and other equipment which generate high frequency noise.
- Only the same bank wireless systems can be used in the same location. Avoid using the systems in combination with those of different banks because interference or noise could be generated.
- Wireless receivers to be installed in the same location must differ from each other in channel number. Setting them for the same channel number could result in noise. Wireless microphones must be identical to wireless receivers in both bank and channel numbers.
- When using two or more wireless microphones, keep them at least 50 cm away from each other to avoid malfunctions or noise.
- Keep the wireless microphone at least 3 m away from the receiving antenna. Using the microphone in close proximity to the antenna could result in malfunctions or noise.
- Be sure to connect at least two receiving antennas (one each for Channels A and B).

## 5. NOMENCLATURE AND FUNCTIONS

[Front]

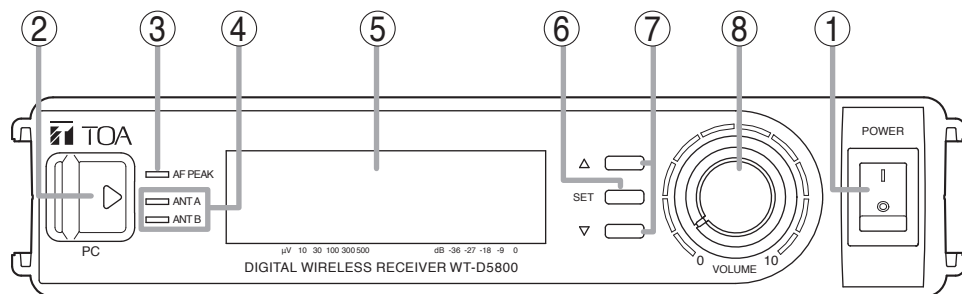

### 1. Power switch

Pushing this switch to the ON position ( **I** ) turns the power ON, while pushing it to the OFF position ( **O** ) turns the power OFF.

### 2. USB connector for PC use

Used to connect the unit to a PC with the installed software.

### 3. AF peak indicator

Lights when the output level reaches the point of about 3 dB below the clipping level.

### 4. Reception indicators

Depending on the state of reception, the indicator's lit or unlit state will be determined as follows.

When being received normally*1	Lit (green)
When abnormal reception occurs*2	Lit (red)
When reception does not occur	Unlit

\*1 While receiving radio waves and when audio output is in a ready state

\*2 While receiving radio waves, in the state when audio output does not occur

### 5. LCD screen

The status of each function is displayed, such as for reception frequency, security setting, and battery level, etc.

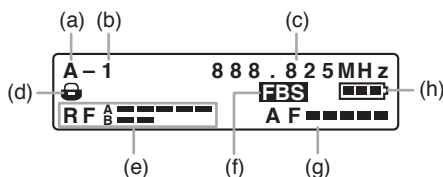

(a) Bank number

(b) Channel number

(c) Frequency

(d) Lock icon

Displayed when the Encryption function is enabled.

(e) RF meters A and B

Indicate the received radio wave strength in meters.

"A" indicates the strength of radio waves received by the 'A' system antenna, while "B" indicates the radio wave strength of the 'B' system antenna.

(f) FBS indication

Displayed when the FBS function is enabled.

(g) AF meter

Indicates the received microphone audio signal level in meters.

(h) Remaining battery capacity indicator

Indicates the microphone's remaining battery capacity.

: Battery power is full charge.

: Battery power depletion has started.

: Battery power is almost depleted, and battery replacement is required.

### 6. Set key

Brings the unit in setting mode when pressed for about 1 second in normal operating state. In setting mode, pressing this key determines the selected setting item and registers its contents.

## 7. Up/Down keys

Select the setting items displayed on the LCD screen (5).  
LCD screen (5).

## 8. Volume control

Adjusts an output level.

[Rear]

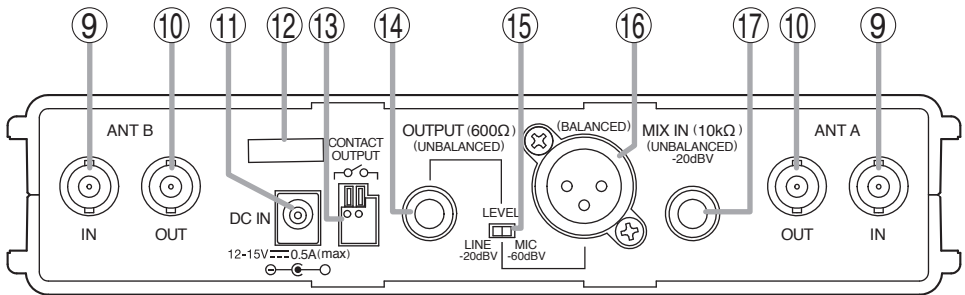

## 9. Antenna inputs A and B

75 Ω, BNC

For the wireless system covering a relatively narrow area, use the supplied two rod antennas, which should be set up at a 45° angle outwards from a vertical line.

## 10. Antenna distribution outputs A and B

75 Ω, BNC

Output the same signals as those which are input to Antenna inputs A, B (9). Used for an RF cascade connection.

## 11. DC input jack

Connect the power cable of the supplied AC adapter or equivalent to this jack.

## 12. Cable hanger

Hook the power cable onto this part.

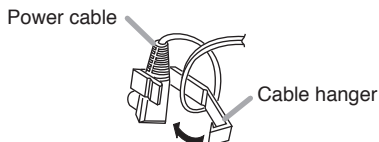

## 13. Contact output terminal

Push-type terminal block

Depending on the state of the microphone, the make contact is output.

## 14. AF output

-20 dB\*/-60 dB\* selectable, unbalanced, phone jack.

## 15. AF output level selector

Sets the output level from the AF outputs by selecting either MIC (-60 dB\*/600 Ω) or LINE (-20 dB\*/600 Ω).

## 16. AF output

-20 dB\*/-60 dB\* selectable, balanced, XLR connector, male type (pin #2: Hot)

## 17. AF mixing input

-20 dB\*, 10 kΩ, unbalanced, phone jack.  
Connects to other unit's AF output.

\* 0 dB = 1 V



## 6. RACK MOUNTING

- When mounting one WT-D5800 unit, use an optional mounting kit MB-WT3.

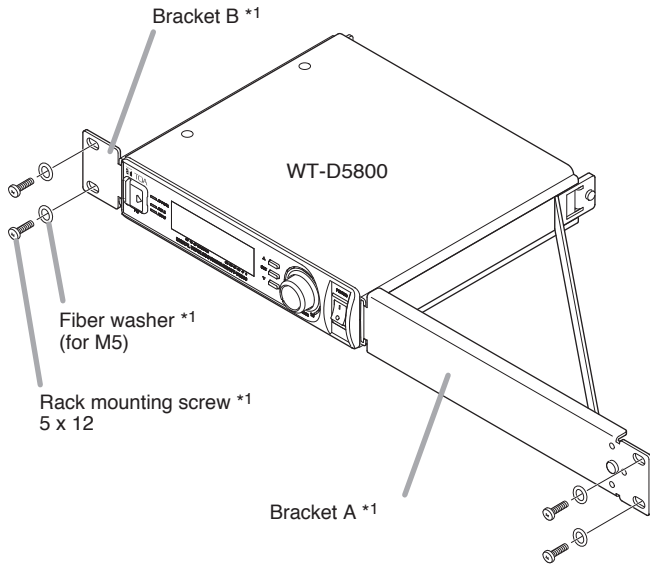

\*1 Component parts of the MB-WT3.

- When mounting two WT-D5800 units, use an optional mounting kit MB-WT4.

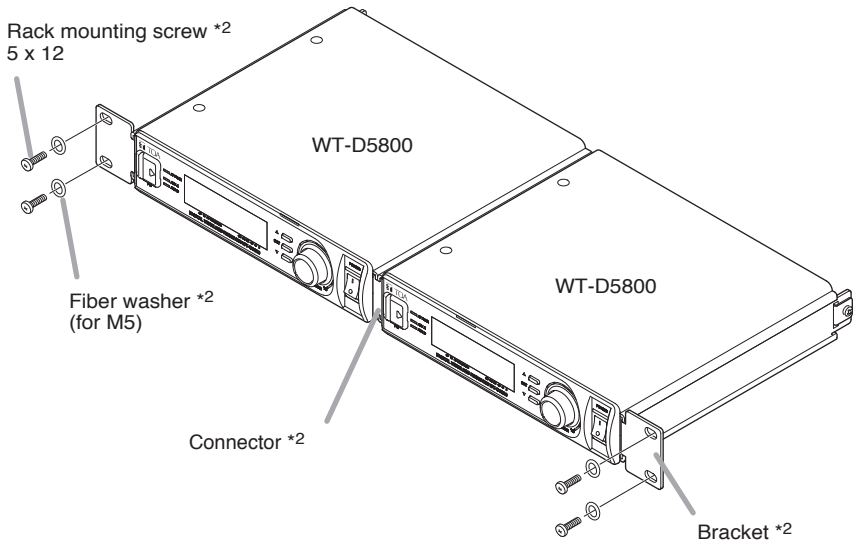

\*2 Component parts of the MB-WT4.

## 7. CONNECTION EXAMPLES

Be sure to connect at least two receiving antennas (one each for Channels A and B).

### 7.1. Example 1

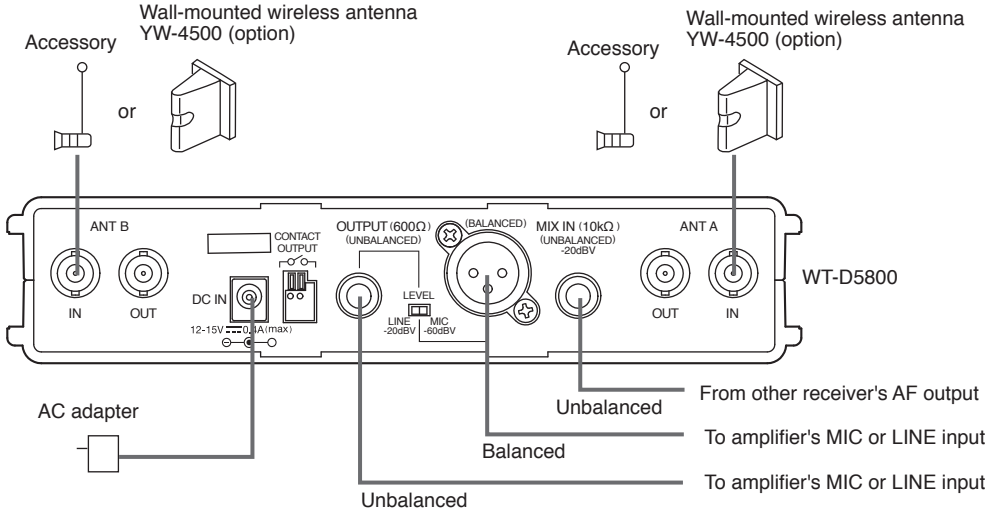

### 7.2. Example 2

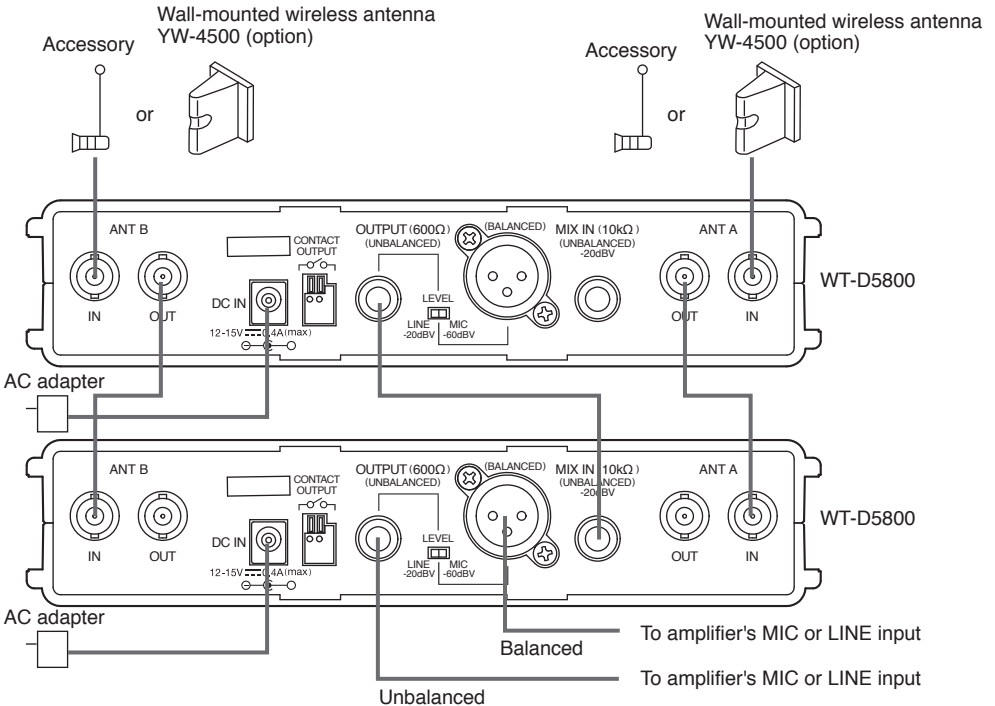

### 7.3. Contact Output Settings

The WT-D5800 unit features no-voltage output contacts, which can be used to control external equipment, such as system PA amplifiers.

#### [Operation trigger (TRIGGER)]

Two types of operation triggers are available for starting and stopping contact outputs: Reception Status (RF ON) and Remaining Battery Capacity Warning (BATT ALARM).

Reception Status ("RF ON") (default setting):

The contact output is enabled when a signal is received normally (when microphone audio can be reproduced), and in other cases (when microphone audio cannot be reproduced) it is not enabled.

Remaining Battery Capacity Warning ("BATT ALARM"):

The contact output is enabled when the remaining battery capacity warning is activated (when the battery needs to be charged or replaced), and in other cases (when charging or replacement are not required) it is not enabled.

#### [Output type (TYPE)]

The contact has two types of output: Continuous Make ("LEVEL") and Pulse Make ("ONE-SHOT").

Continuous Make ("LEVEL") (default setting):

Signal is output immediately after the operation trigger is enabled, and signal output is stopped two seconds after the operation trigger is disabled.

Pulse Make ("ONE-SHOT"):

Signal is output immediately after the operation trigger is enabled, and signal output is stopped after one second has elapsed.

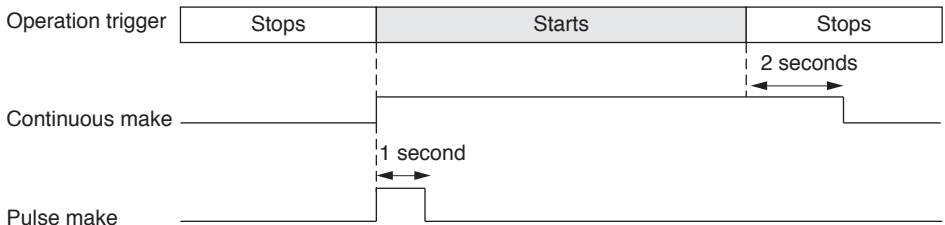

#### [Output control (ENABLE/DISABLE)]

"ON" or "OFF" can be selected for the output control of a contact ("ENABLE/DISABLE").

ON (default setting): Contact is output in response to an operation trigger.

OFF: Contact is not output, with no response to the operation trigger.

#### Tip

Setting contents are retained even if the power is switched OFF.

#### Notes

- When the operation trigger is set to "Remaining Battery Capacity Warning" mode, if the wireless microphone's power is switched off, the remaining battery capacity cannot be detected, resulting in the contact output being stopped.
- The contact output also stops in any of the following cases:
  - Channel scanning in progress.
  - Channel scanning and spectrum scanning by the supplied WT-D5800 Maintenance Software are in progress.

## 8. FUNCTION SETTINGS

Settings are performed in setting mode.

### [Keys used in setting mode]

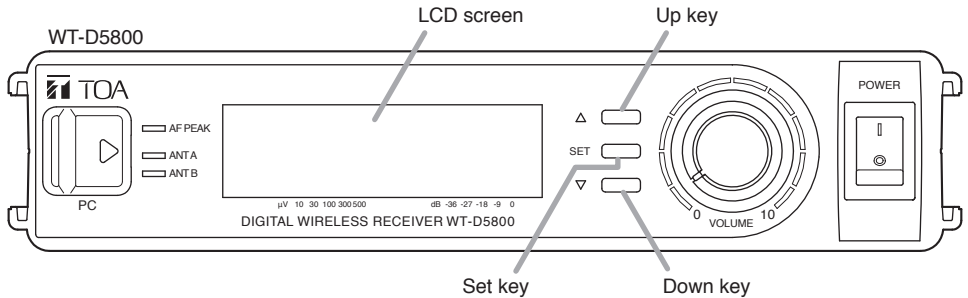

### 8.1. Placing the Unit in Setting Mode

**Step:** Press the Set key for about 1 second.  
The unit is placed in setting mode.

The normal operating state



Setting mode



Pressed for about 1 second

### 8.2. Setting Items Displayed on the LCD Screen in Setting Mode

The display cycles through the indications "BANK," "CHANNEL," "ENCRYPTION," "CODE," "PAIRING," "FBS," "ANT ATTN," "EQ PRESET," "CONTACT OUT," "CHANNEL SCAN," "LCD CONTRAST," "MODEL INFO" and "EXIT" with each depression of the Up key, or the Down key for the reverse action.

#### Notes

- The "CODE" indication is not displayed while the Encryption Function is enabled.
- The "PAIRING" indication is not displayed while the Encryption Function is disabled.

## 8.3. Function Settings

### 8.3.1. Bank number setting

**Step 1.** In setting mode, select the setting item "BANK" with the Up or Down key.

**Step 2.** Press the Set key, and the LCD screen displays the currently-set bank number and frequency with the prefix "√" indication. (Example: √ 7 805.000 MHz)

**Step 3.** Select the desired bank number with the Up or Down key.

The display cycles through the contents with each depression of the Up or Down key.

**Note**

When leaving the original bank number unchanged, select "EXIT" with Up or Down key and press the Set key. Then, the display returns to the "BANK" indication.

**Step 4.** Press the Set key to register the selected bank number.

This terminates the bank number setting, and the display returns to the "BANK" indication.

**Step 5.** When any other setting is not needed, select "EXIT" with the Up or Down key and press the Set key.

The unit returns to the normal operating state.

**Note**

When another setting is needed, select the necessary setting item with the Up or Down key and press the Set key.

### 8.3.2. Channel number setting

**Step 1.** In setting mode, select the setting item "CHANNEL" with the Up or Down key.

**Step 2.** Press the Set key, and the LCD screen displays the currently-set channel number and frequency with the prefix "√" indication. (Example: √ 8 805.125 MHz)

**Step 3.** Select the desired channel number with the Up or Down key.

The display cycles through the contents with each depression of the Up or Down key.

**Note**

When leaving the original channel number unchanged, select "EXIT" with Up or Down key and press the Set key. Then, the display returns to the "CHANNEL" indication.

**Step 4.** Press the Set key to register the selected channel number.

This terminates the channel number setting, and the display returns to the "CHANNEL" indication.

**Step 5.** When any other setting is not needed, select "EXIT" with the Up or Down key and press the Set key.

The unit returns to the normal operating state.

**Note**

When another setting is needed, select the necessary setting item with the Up or Down key and press the Set key.

### 8.3.3. Encryption setting

This setting enables the Encryption Function, which prevents the contents of communications between the WT-D5800 unit and the microphone from being read externally.

#### Notes

- Complete the bank and channel settings for the WT-D5800 unit and the microphone before performing the encryption setting.
- Be sure to perform pairing setting (see p. 15) after the Encryption Function has been enabled. The Encryption Function will not work properly if the WT-D5800 and the microphone are not properly associated with each other by way of the pairing setting.

**Step 1.** In setting mode, select the setting item "ENCRYPTION" with the Up or Down key.

**Step 2.** Press the Set key, and the LCD screen displays the current setting.

**Step 3.** Select "ON" or "OFF" with the Up or Down key.

#### Note

When leaving the setting unchanged, select "EXIT" with Up or Down key and press the Set key. Then, the display returns to the "ENCRYPTION" indication.

**Step 4.** Press the Set key to register the setting.

This terminates the encryption setting, and the display returns to the "ENCRYPTION" indication.

**Step 5.** When any other setting is not needed, select "EXIT" with the Up or Down key and press the Set key.

The unit returns to the normal operating state.

#### Note

When another setting is needed, select the necessary setting item with the Up or Down key and press the Set key.

#### Tip

The lock icon is displayed on the LCD screen when the Encryption function is enabled.

### 8.3.4. Pairing setting

Perform pairing setting for the WT-D5800 unit and the microphone or transmitter only after the Encryption Function has been enabled.

#### Tips

- The symbol **M** means microphone operation, and **R** means receiver operation.
- The illustrations in this section show the WM-D5200.

- M Step 1.** With the battery compartment cover removed, switch ON the microphone power switch and confirm that the Encryption indicator is unlit. If the indicator is lit, switch encryption from ON to OFF (see p. 17).

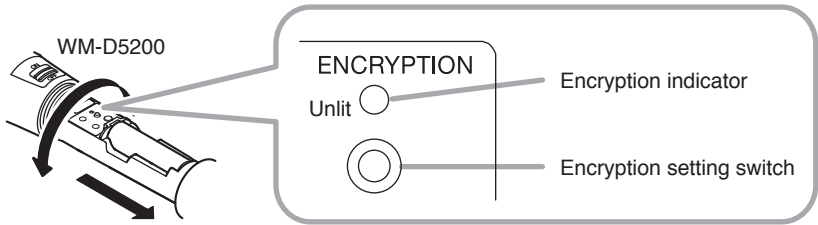

- M Step 2.** Switch OFF the microphone power switch.

- R Step 3.** In setting mode, select the setting item "PAIRING" with the Up or Down key.

#### Note

The "PAIRING" indication is not displayed while the Encryption Function is disabled, making it impossible to perform the pairing setting.

- R Step 4.** Press the Set key, and the LCD screen displays the "HOLD THE SET KEY" indication.

- M Step 5.** Switch ON the microphone power switch while holding down the microphone's Encryption setting switch (continue holding until **Step 7**). Confirm that the microphone's Encryption indicator is flashing. An ID number is transmitted while the microphone's Encryption setting switch is held down.

- R Step 6.** Hold down the Set key to start pairing. The "RECEIVING" indication is displayed on the LCD screen during pairing.

#### Tip

To interrupt the pairing setting, release the Set key.



**M Step 7.** After confirming that the WT-D5800's LCD display has switched to the "SUCCESS" indication, release the microphone's Encryption setting switch.

**R Step 8.** Release the Set key.  
The LCD display returns to the "EXIT" indication.

**M Step 9.** Confirm that the microphone's Encryption indicator is lit.  
The encryption setting is now ON.

**M Step 10.** Switch off the microphone.

**R Step 11.** Press the Set key. Then, the display returns to the "PAIRING" indication.

**R Step 12.** When any other setting is not needed, select "EXIT" with the Up or Down key and press the Set key.  
The unit returns to the normal operating state.

**Note**

When another setting is needed, select the necessary setting item with the Up or Down key and press the Set key.

**Notes**

- Do not switch OFF the power to the microphone or receiver during setting.
- Hold down the microphone's Encryption setting switch and the receiver's Set key until the "SUCCESS" indication appears on the receiver's LCD screen.  
If the microphone's Encryption setting switch or the receiver's Set key is released while the "RECEIVING" indication is displayed on the receiver's screen, the receiver will not have correctly received the new ID number, leaving the ID number unchanged from the previous value. To match the receiver ID number with the microphone ID number, switch OFF the microphone's encryption setting, then repeat **Steps 1 – 11** above.

**Tips**

- Settings can be performed regardless of whether the microphone or receiver Encryption setting switch was depressed first.
- The receiver does not output audio during ID number setting, even if it receives a radio signal from the microphone.

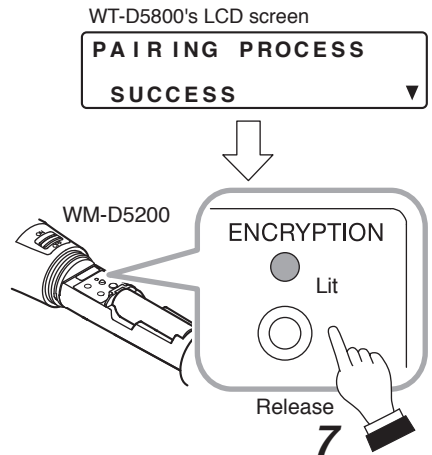



**M** [Switching the Microphone Encryption function from ON to OFF]

**Step 1.** With the battery compartment cover removed, switch ON the microphone power switch and confirm that the Encryption indicator is lit.

**Step 2.** Switch OFF the power switch.

**Step 3.** Switch ON the microphone power switch while holding down the Encryption setting switch.

**Note**

Do not switch OFF the microphone power switch during setting.

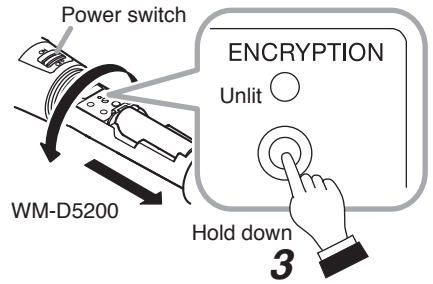

**Step 4.** Confirm that the Encryption indicator has extinguished, then release the Encryption setting switch.  
The encryption setting switches to OFF.

### 8.3.5. Code setting

Perform code setting by selecting a code from among 10 different numbers. Only the audio of the microphone assigned with the same code as the WT-D5800 unit can be output.

#### Notes

- Complete the bank and channel settings for the WT-D5800 unit and the microphone before performing the code setting.
- Enabling the Encryption Function after completion of the code setting will invalidate the code setting.

**Step 1.** In setting mode, select the setting item "CODE" with the Up or Down key.

#### Note

The "CODE" indication is not displayed while the Encryption Function is enabled, making it impossible to set the code.

**Step 2.** Press the Set key, and the LCD screen displays the current setting.

**Step 3.** Select the desired code number with the Up or Down key.

The display cycles through the contents with each depression of the Up or Down key.

#### Note

When leaving the original code number unchanged, select "EXIT" with Up or Down key and press the Set key. Then, the display returns to the "CODE" indication.

**Step 4.** Press the Set key to register the setting.

This terminates the code setting, and the display returns to the "CODE" indication.

**Step 5.** When any other setting is not needed, select "EXIT" with the Up or Down key and press the Set key.

The unit returns to the normal operating state.

#### Note

When another setting is needed, select the necessary setting item with the Up or Down key and press the Set key.

### 8.3.6. Feedback suppressor (FBS) setting

Acoustic feedback can be automatically suppressed.

**Step 1.** In setting mode, select the setting item "FBS" with the Up or Down key.

**Step 2.** Press the Set key, and the LCD screen displays the current setting.

**Step 3.** Select "ON" or "OFF" with the Up or Down key.

**Note**

When leaving the setting unchanged, select "EXIT" with Up or Down key and press the Set key. Then, the display returns to the "FBS" indication.

**Step 4.** Press the Set key to register the setting.

This terminates the FBS setting, and the display returns to the "FBS" indication.

**Step 5.** When any other setting is not needed, select "EXIT" with the Up or Down key and press the Set key.

The unit returns to the normal operating state.

**Note**

When another setting is needed, select the necessary setting item with the Up or Down key and press the Set key.

**Tip**

The FBS indication is displayed on the LCD screen when the FBS function is enabled.

### 8.3.7. Antenna attenuator (ANT ATTEN) setting

This setting reduces radio interference by attenuating the signal to the antenna input terminal by 10 dB.

**Step 1.** In setting mode, select the setting item "ANT ATTEN" with the Up or Down key.

**Step 2.** Press the Set key, and the LCD screen displays the "ANT A" indication.

**Step 3.** Select "ANT A" or "ANT B" with the Up or Down key.

**Note**

When leaving the original ANT ATTEN setting unchanged, select "EXIT" with Up or Down key and press the Set key. Then, the display returns to the "ANT ATTEN" indication.

**Step 4.** Press the Set key.

**Step 5.** Select "0 dB" or "-10 dB" with the Up or Down key.

**Step 6.** Press the Set key to register the setting.

**Step 7.** Repeat **Steps 3 – 6** to perform the setting for another antenna input.

**Step 8.** When any other setting is not needed, select "EXIT" with the Up or Down key and press the Set key.

The unit returns to the normal operating state.

**Note**

When another setting is needed, select the necessary setting item with the Up or Down key and press the Set key.

### 8.3.8. EQ setting

This setting permits adjustment of the WT-D5800 unit's audio output for a more easily heard sound quality. (Default setting: OFF)

**Step 1.** In setting mode, select the setting item "EQ PRESET" with the Up or Down key.

**Step 2.** Press the Set key, and the LCD screen displays the current setting.

**Step 3.** Select the desired EQ setting with the Up or Down key.

The display cycles through the contents with each depression of the Up or Down key.

**Note**

When leaving the original EQ setting unchanged, select "EXIT" with Up or Down key and press the Set key. Then, the display returns to the "EQ PRESET" indication.

**Tip**

EQ setting selections are shown for each microphone model number.

**Step 4.** Press the Set key to register the setting.

This terminates the EQ setting, and the display returns to the "EQ PRESET" indication.

**Step 5.** When any other setting is not needed, select "EXIT" with the Up or Down key and press the Set key.

The unit returns to the normal operating state.

**Note**

When another setting is needed, select the necessary setting item with the Up or Down key and press the Set key.

### 8.3.9. Contact out setting

Make contacts can be provided from the WT-D5800 unit depending on the microphone status. See p. 11 for details regarding each setting.

**Step 1.** In setting mode, select the setting item "CONTACT OUT" with the Up or Down key.

**Step 2.** Perform ENABLE/DISABLE setting.

**2-1.** Press the Set key, and the LCD screen displays the "ENABLE/DISABLE" indication.

**Note**

When leaving the original CONTACT OUT setting unchanged, select "EXIT" with Up or Down key and press the Set key. Then, the display returns to the "CONTACT OUT" indication.

**2-2.** Press the Set key, and the LCD screen displays the current setting.

**2-3.** Select "ON" or "OFF" with the Up or Down key.

**2-4.** Press the Set key to register the setting.

This terminates the ENABLE/DISABLE setting, and the display returns to the "ENABLE/DISABLE" indication.

**Note**

When leaving the original ENABLE setting unchanged, select "EXIT" with Up or Down key and press the Set key. Then, the display returns to the "ENABLE/DISABLE" indication.

**Step 3.** Perform TYPE setting.

**3-1.** Select "TYPE" with the Up or Down key.

**3-2.** Press the Set key, and the LCD screen displays the current setting.

**3-3.** Select "LEVEL" or "ONE-SHOT" with the Up or Down key.

**3-4.** Press the Set key to register the setting.

This terminates the TYPE setting, and the display returns to the "TYPE" indication.

**Note**

When leaving the original TYPE setting unchanged, select "EXIT" with Up or Down key and press the Set key. Then, the display returns to the "TYPE" indication.

**Step 4.** Perform TRIGGER setting.

**4-1.** Select "TRIGGER" with the Up or Down key.

**4-2.** Press the Set key, and the LCD screen displays the current setting.

**4-3.** Select "RF ON" or "BATT ALARM" with the Up or Down key.

**4-4.** Press the Set key to register the setting.

This terminates the TRIGGER setting, and the display returns to the "TRIGGER" indication.

**Note**

When leaving the original TRIGGER setting unchanged, select "EXIT" with Up or Down key and press the Set key. Then, the display returns to the "TRIGGER" indication.

**Step 5.** Select "EXIT" with the Up or Down key and press the Set key.  
The display returns to the "CONTACT OUT" indication.

**Step 6.** When any other setting is not needed, select "EXIT" with the Up or Down key and press the Set key.

The unit returns to the normal operating state.

**Note**

When another setting is needed, select the necessary setting item with the Up or Down key and press the Set key.

### 8.3.10. Bank and channel detection

Idle frequencies are automatically scanned and usable frequencies are displayed.

**Step 1.** In setting mode, select the setting item "CHANNEL SCAN" with the Up or Down key.

**Step 2.** Press the Set key, and the LCD screen displays the "START" indication.

**Step 3.** Press the Set key to start bank and channel detection.

Bank and channel detection begins, and an idle bank and channel number is displayed on the bank selection screen.

On the bank selection screen, idle frequencies are displayed by bank number and channel number for each bank number.

If no idle channel is detected, "NO VACANT CHANNEL" is displayed.

#### **Tips**

- The "CHANNEL SCANNING" indication is displayed on the LCD screen during channel scanning.
- Pressing the Set key while channel scanning is in progress stops the channel scan and causes the partial scan results to be displayed.  
In this event, the "NO VACANT CHANNEL" indication is displayed for unscanned banks.

**Step 4.** Select the desired bank number with the Up or Down key and press the Set key.

The channel number setting screen will appear.

#### **Note**

When leaving the original bank and channel setting unchanged, select "EXIT" with Up or Down key and press the Set key. Then, the display returns to the "CHANNEL SCAN" indication.

**Step 5.** Select the desired channel number with the Up or Down key and press the Set key.

This terminates the bank and channel detection, and the display returns to the "CHANNEL SCAN" indication.

#### **Note**

When setting the channel numbers for other bank numbers, select "EXIT" to return the display to the bank selection screen.

**Step 6.** When any other setting is not needed, select "EXIT" with the Up or Down key and press the Set key.

The unit returns to the normal operating state.

#### **Note**

When another setting is needed, select the necessary setting item with the Up or Down key and press the Set key.

### 8.3.11. LCD contrast adjustment setting

This setting adjusts the WT-D5800 unit's LCD screen contrast.

**Step 1.** In setting mode, select the setting item "LCD CONTRAST" with the Up or Down key.

**Step 2.** Press the Set key, and the currently-set contrast adjustment display appears on the LCD screen.

**Step 3.** Select the desired contrast level with the Up or Down key.

**Step 4.** Press the Set key to register the selected contrast level.

This terminates the contrast setting, and the display returns to the "LCD CONTRAST" indication.

**Step 5.** When any other setting is not needed, select "EXIT" with the Up or Down key and press the Set key.

The unit returns to the normal operating state.

**Note**

When another setting is needed, select the necessary setting item with the Up or Down key and press the Set key.

### 8.3.12. Confirming firmware version

Confirm the WT-D5800 unit's firmware version number.

**Step 1.** In setting mode, select the setting item "MODEL INFO" with the Up or Down key.

**Step 2.** Press the Set key to display the firmware version.

**Step 3.** Press the Set key again to exit the firmware display mode, and the display returns to the "MODEL INFO" indication.

**Step 4.** When any other setting is not needed, select "EXIT" with the Up or Down key and press the Set key.

The unit returns to the normal operating state.

**Note**

When another setting is needed, select the necessary setting item with the Up or Down key and press the Set key.

## 9. OPERATION

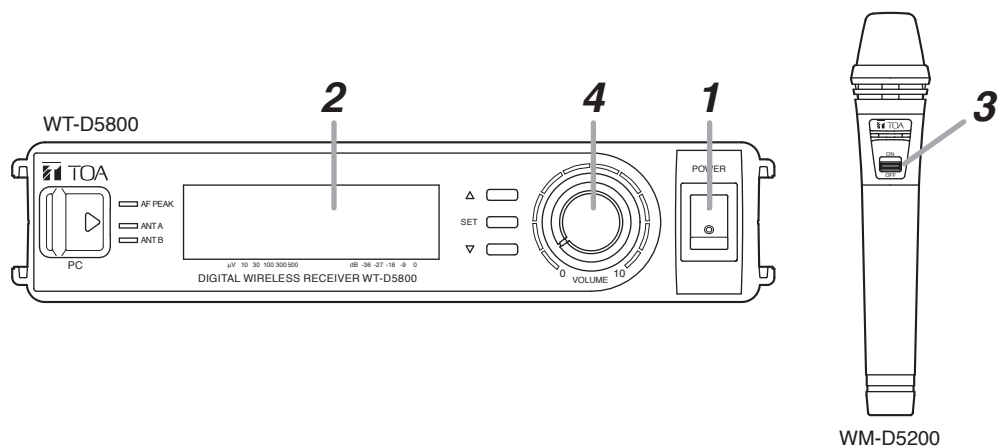

- Step 1.** Turn the power on.  
The LCD screen comes to display the receiving frequency and RF/AF levels.
- Step 2.** Confirm that the wireless microphone and this unit are identical in the bank and channel number.
- Step 3.** Set the wireless microphone power switch to the ON position.  
The reception indicator lights green when the receiver receives the same frequency signal.
- Step 4.** Adjust the volume control.  
The output level increases as the control is rotated clockwise, and decreases as rotated counterclockwise.
- Tip**  
The knob is initially set at the two o'clock position, thus make adjustment to the desired volume. When the AF peak indicator is lit at all times, lower the volume.
- Step 5.** After the usage of the unit, turn OFF the power and the wireless microphone power switch.

### Note

Depending on the setting of the contact output, when you set the wireless microphone power switch to ON, there is the case that the external device connected to the unit may be operational with the contact output from the unit.



# 10. HOW TO CHECK AND DEAL WITH INTERFERENCE

## [Order of Actions (Action Flowchart)]

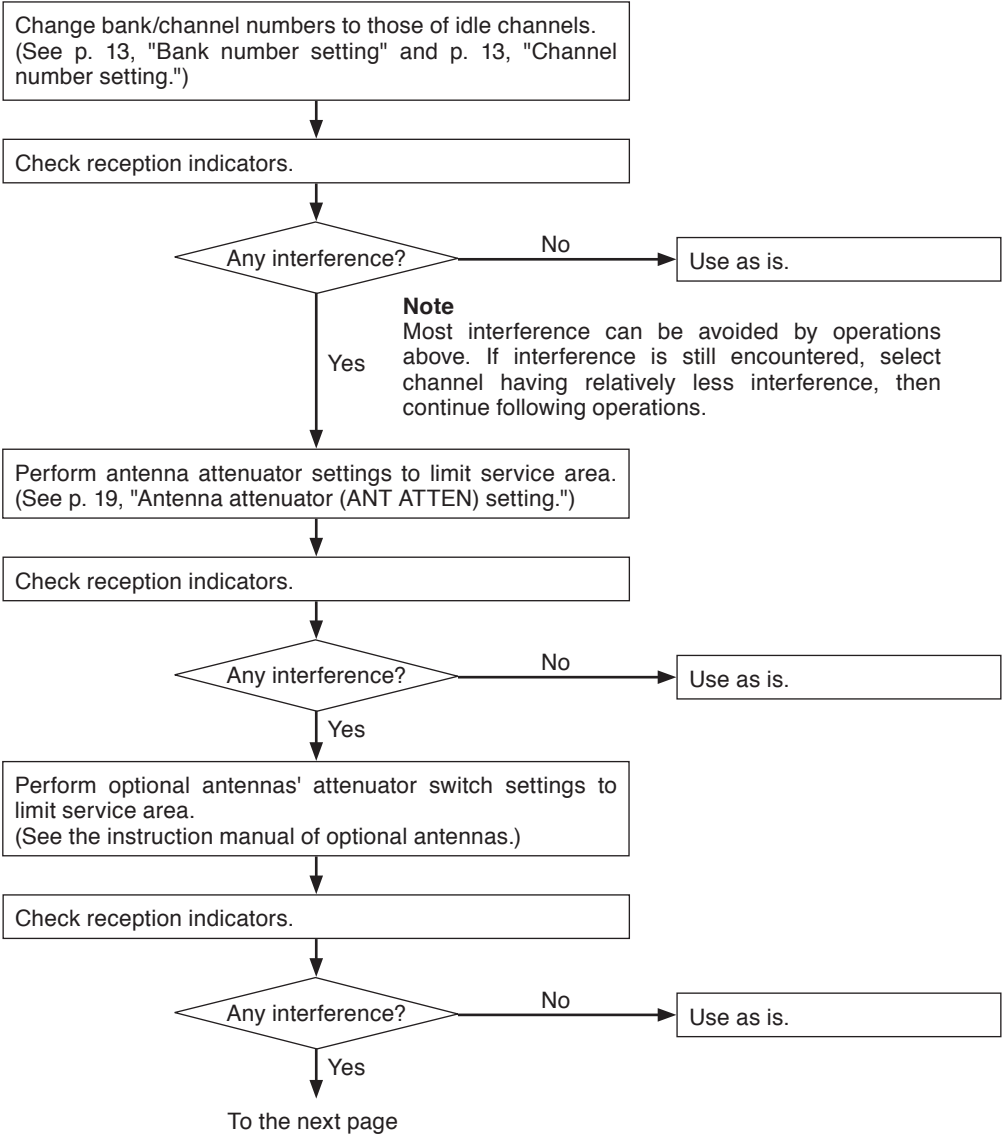

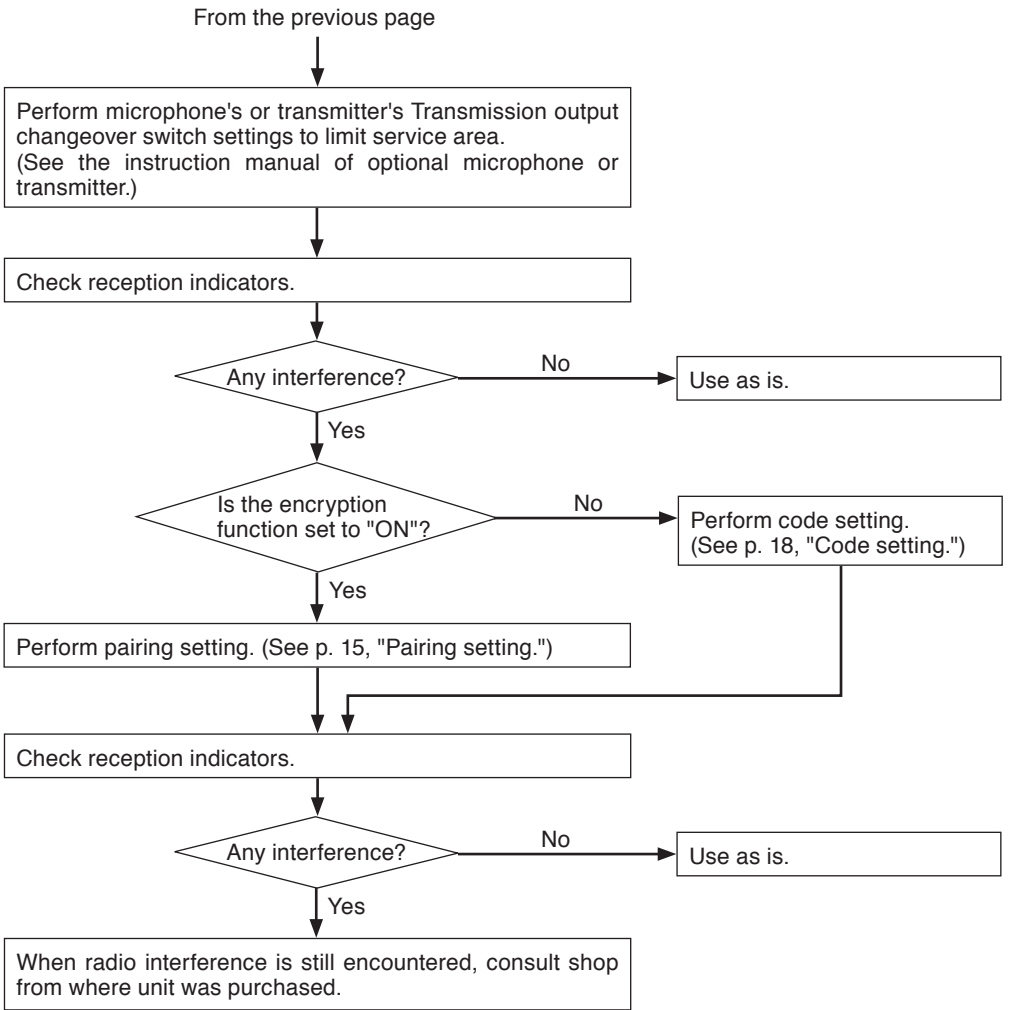

# 11. SPECIFICATIONS

Power Source	AC mains (supplied AC adapter must be used)
Current Consumption	350 mA (13.5 V)
Version and Receiving Frequency	WT-D5800 -A2: 694 – 703 MHz WT-D5800 EC4, EC7: 798 – 832 MHz (803 – 806 MHz for Thailand) WT-D5800 EG1, GG1, -G1: 606 – 636 MHz WT-D5800 RH1: 576 – 606 MHz
Channel Selectable	160 selectable frequencies
Receiving System	Double super-heterodyne
Diversity system	Space diversity (digital diversity)
Mixing Output	MIC/LINE (selectable): –60 dB* (MIC)/–20 dB* (LINE), 600 Ω phone jack (unbalanced), 600 Ω XLR-3-32 type connector (balanced)
Mixing Input	–20 dB*, 10 kΩ, unbalanced, phone jack
Antenna Input	75 Ω, BNC (phantom powering for antenna), 9 V DC, 30 mA (max)
Antenna Output	75 Ω, BNC (Gain 0 dB)
Contact Output	1 channel, no-voltage make contact output, withstand voltage: 30 V DC, control current 0.5 A max terminal block (2 pins)
Receiving Sensitivity	24 dBμV or less (Bit error rate: 1E-5 or less)
Antenna Input Attenuator	0 dB/–10 dB switchable
Indicator	Audio (5 steps), RF (5 steps), ANT A/B, Audio (peak), Battery alarm
Frequency Response	50 Hz – 12 kHz
Total Harmonic Distortion	0.5 % or less
Function	Frequencies scanning, Feedback suppressor, Equalizer (optimizing each compatible microphone)
ID Selectable	10 patterns
Operating Temperature	–10 to +50 °C (14 to 122 °F)
Operating Humidity	30 to 85 %RH (no condensation)
Finish	Resin, black
Dimensions	210 (w) × 44 (h) × 211.9 (d) mm (8.27" × 1.73" × 8.34")
Weight	730 g (1.61 lb)

\* 0 dB = 1V

**Note:** The design and specifications are subject to change without notice for improvement.

### • Accessories

[WT-D5800 EC7, WT-D5800 EG1,  
WT-D5800 GG1, WT-D5800 RH1]

AC adapter ..... 1  
Whip antenna ..... 2  
Rubber foot ..... 4

[WT-D5800 EC4, WT-D5800 -G1, WT-D5800 -A2]

Whip antenna ..... 2  
Rubber foot ..... 4

**Note:** As for the usable AC adapter, consult your TOA dealer.

### • Optional products

Rack mounting bracket kit: MB-WT3 (for rack mounting one WT-D5800 unit)  
MB-WT4 (for rack mounting two WT-D5800 units)

### Note

The WT-D5800 cannot communicate with the TRANTEC Wireless System (S4 and S5 Series) nor with the TOA Analog Wireless System (WM-5325, WM-5225 etc.).



# DECLARATION OF CONFORMITY

We: TOA Electronics Europe GmbH  
Süderstraße 282, 20537 Hamburg, Germany

as the authorised representative of the

Manufacturer: TOA Corporation  
7-2-1, Minatojima-nakamachi, Chuo-ku, Kobe, Japan 650-0046

declare, under our sole responsibility, that the product

**Product Name: DIGITAL WIRELESS RECEIVER**

**Model Number: WT-D5800**

conforms with following specifications:

RED: EN 301 489-1 V2.2.0 (2017-03)  
EN 301 489-9 V2.1.1 (2017-03)  
EN 300 422-1 V2.1.2 (2017-01)  
EN 62368-1: 2014 + A11: 2017

RoHS: EN 50581: 2012

The product herewith complies with the requirements of the EU directives:

2014/53/EU relating to the radio equipment (RED),  
2011/65/EU and (EU)2015/863 relating to the restrictions of hazardous substances  
(RoHS).

Remark:

This Declaration of Conformity replaces all previous ones of the above model(s).



Hamburg, 20 December 2020  
(place, date)

A handwritten signature in blue ink that reads 'Wolfgang Pein'.

\_\_\_\_\_  
Wolfgang Pein, Managing Director  
(authorised signature)



## SUPPLIER'S DECLARATION OF CONFORMITY

---

We : TOA Electronics, Inc.  
1 Harmon Plaza, Suite 602 Secaucus, New Jersey 07094,  
USA

as the authorised representative of the

Manufacturer: TOA Corporation  
7-2-1, Minatojima-nakamachi, Chuo-ku, Kobe, Japan 650-0046

declare, under our sole responsibility, that the product

**Product Name: DIGITAL WIRELESS RECEIVER**

**Model Number: WT-D5800 RH1**

complies with Part 15 of FCC Rules.

Operation is subject to the following conditions: (1) this device may not cause harmful interference, and (2) this device must accept any interference received, including interference that may cause undesired operation.

Any modification to the unit, unless expressly approved by TOA Electronics, Inc. could void the your authority to operate the equipment.

## COMPLIANCE STATEMENT TO WT-D5800

<b>AT</b> <b>BE</b> <b>CH</b> <b>DE</b>	Österreich Belgien Schweiz Deutschland	Hiermit erklärt TOA Electronics Europe GmbH die Übereinstimmung des Empfängers / Empfangsmoduls mit den grundlegenden Anforderungen und den anderen relevanten Festlegungen der Richtlinie 2014/53/EU. (verantwortlich für die Schweiz: GoWild (Zug); URL: <a href="http://www.gowild.ch">http://www.gowild.ch</a> )
<b>BE</b> <b>CH</b> <b>FR</b> <b>LU</b>	Belgique Suisse France Luxembourg	Par la présente TOA Electronics Europe GmbH déclare que l'appareil récepteur / module de réception est conforme aux exigences essentielles et aux autres dispositions pertinentes de la directive 2014/53/UE. (CH: GoWild (Zug); URL: <a href="http://www.gowild.ch">http://www.gowild.ch</a> )
<b>BE</b> <b>NL</b>	België Nederland	Hierbij verklaart TOA Electronics Europe GmbH dat deze ontvanger / ontvangstmodule in overeenstemming is met de essentiële eisen en de andere relevante bepalingen van richtlijn 2014/53/EU.
<b>BG</b>	Държава	С настоящото TOA Electronics Europe GmbH, декларира, че този приемник / тунер модул е в съответствие със съществените изисквания и другите приложими разпоредби на Директива 2014/53/EC.
<b>CY</b>	Κυπρος	Η TOA Electronics Europe GmbH, δηλώνει ότι ο δέκτης σημάτων/ ραδιοφωνικός δέκτης συνάδει με τις βασικές απαιτήσεις και άλλες σχετικές διατάξεις της Οδηγίας 2014/53/EE.
<b>CZ</b>	Česká republika	TOA Electronics Europe GmbH tímto prohlašuje, že tento přijímač / modul tuneru je ve shodě se základními požadavky a dalšími příslušnými ustanoveními směrnice 2014/53/EU.
<b>DK</b>	Danmark	Undertegnede TOA Electronics Europe GmbH erklærer herved, at følgende udstyr Modtager / Modtager Modul overholder de væsentlige krav og øvrige relevante krav i direktiv 2014/53/EU.
<b>EE</b>	Eesti	Käesolevaga TOA Electronics Europe GmbH, teatab, et see vastuvõtja / tuuner moodul on vastavus oluliste nõuetele ja teiste asjakohastele sätetele direktiivi 2014/53/EL.
<b>ES</b>	España	TOA Electronics Europe GmbH declara que el receptor / sintonizador inalámbrico cumple con los requisitos esenciales y otras disposiciones aplicables o exigibles en la Directiva 2014/53/UE.
<b>FI</b>	Suomi / Finland	TOA Electronics Europe GmbH vakuuttaa täten että tämä vastaanotin / viritinmoduli on direktiivin 2014/53/EU oleellisten vaatimusten ja sitä koskevien direktiivin muiden ehtojen mukainen.
<b>UK</b> <b>IE</b>	United Kingdom Eire	Hereby, TOA Electronics Europe GmbH, declares that this receiver / tuner module is in compliance with the essential requirements and other relevant provisions of Directive 2014/53/EU.

<b>GR</b>	Ελλάδα	Με την παρούσα η εταιρεία TOA Electronics Europe GmbH δηλώνει ότι ο ραδιοφωνικός δέκτης/ μονάδα δέκτη συμμορφώνεται με τις ουσιαστικές απαιτήσεις και τις λοιπές σχετικές διατάξεις της οδηγίας 2014/53/ΕΕ.
<b>HR</b>	Hrvatska	Ovime, TOA Electronics Europe GmbH, izjavljuje, da je ovaj prijemnik/ modul prijemnika u skladu s osnovnim zahtjevima i relevantnim odredbama direktive 2014/53/EU.
<b>HU</b>	Magyarország	A TOA Electronics Europe GmbH ezennel kijelenti, hogy ez a vevőkészülék megfelel az 2014/53/EU Irányelv alapvető követelményeinek és egyéb vonatkozó rendelkezéseinek.
<b>IT CH</b>	Italia Svizzera (Italian)	Con la presente TOA Electronics Europe GmbH dichiara che questo Ricevitore / Modulo sintonizzatore è conforme ai requisiti essenziali ed alle altre disposizioni pertinenti stabilite dalla direttiva 2014/53/UE.
<b>LT</b>	Lietuva	Šiuo, Toa Electronics Europe GmbH ", deklaruoja, kad šis imtuvas / imtuvas modulis atitinka esminius reikalavimus ir kitas susijusias nuostatas Direktyvos 2014/53/ES.
<b>LV</b>	Latvija	TOA Electronics Europe GmbH, deklarē, ka šis uztvērējs / raidītāja modulis atbilst būtiskajām prasībām un citiem ar to saistītajiem noteikumiem Direktīvā 2014/53/ES.
<b>MT</b>	Malta	TOA Electronics Europe GmbH tistqarr li r-riċevitur u t-tuner module (il-modulu li jagħžel il-frekwenzi) jissodisfaw l-obbligi neċessarji u provvedimenti oħra relevant tad-direttiva 2014/53/UE.
<b>NO</b>	Norway (Norwegian)	TOA Electronics Europe GmbH erklærer herved, at denne mottagermodul / radio er i samsvar med de vesentlige egenskapene og øvrige relevante krav i direktiv 2014/53/EU. (N: Scandec Systemer AS, URL: www.scandecsystemer.no)
<b>PL</b>	Polska	My, TOA Electronics Europe GmbH, niniejszym deklarujemy, iż ten odbiornik/moduł tunera jest zgodny z zasadniczymi wymaganiami oraz innymi stosowanymi postanowieniami Dyrektywy 2014/53/UE.
<b>PT</b>	Portugal	TOA Electronics Europe GmbH declara que este Receptor / Sintonizador está conforme com os requisitos essenciais e outras disposições da Directiva 2014/53/UE.
<b>RO</b>	Romania	Prin aceasta TOA Electronics Europe GmbH declara ca acest modul receptor / tuner este in conformitate cu cerintele esentiale si cu alte prevederi relevante ale Directivei 2014/53/UE.
<b>SE</b>	Sverige (Swedish)	Härmed intygar TOA Electronics Europe GmbH att denna Mottagare / Radio modul står i överensstämmelse med de väsentliga egenskapskrav och övriga relevanta bestämmelser som framgår av direktiv 2014/53/EU.
<b>SI</b>	Slovenija	S tem, TOA Electronics Europe GmbH, izjavlja, da je ta sprejemnik / tuner modul v skladu z bistvenimi zahtevami in drugimi ustreznimi določbami Direktive 2014/53/EU.
<b>SK</b>	Štát	TOA Electronics Europe GmbH týmto prehlasuje, že tento prijímač/ modul tunera je v zhode so základnými požiadavkami a ďalšími príslušnými ustanoveniami smernice 2014/53/EÚ.

**INTENDED USE OF**
**WT-D5800**

<b>AT BE CH DE</b>	Österreich Schweiz Deutschland	<b>WICHTIGER HINWEIS!</b>	<p>Der Gebrauch dieses Funkempfängers für andere Zwecke als zum Empfang eines Tonsignals von einem passenden Funkmikrofon ist nicht zulässig.</p> <p>Dieses Gerät arbeitet auf in der europäischen Gemeinschaft (EU) nicht harmonisierten Frequenzen. Abhängig vom geografischen Gebiet dürfen bestimmte Frequenzen legal mit oder ohne Autorisierung / individueller Lizenz entsprechend der beigefügten Frequenztafel genutzt werden.</p>
<b>BE CH FR LU</b>	Belgique Suisse France Luxembourg	<b>AVIS IMPORTANT!</b>	<p>Ne pas utiliser les récepteurs HF pour une réception du signal audio provenant d' un appareil, autre que les microphones prévus à cet effet.</p> <p>Cet appareil utilise des fréquences d'émission qui ne sont pas harmonisées à travers la Communauté Européenne (EU). En fonction du lieu géographique certaines fréquences peuvent être utilisée de façon légale avec ou sans autorisation / licence individuelle comme décrit dans le tableau des fréquences.</p>
<b>BE NL</b>	België Nederland	<b>BELANGRIJKE AANWIJZING!</b>	<p>Het is niet toegestaan deze ontvanger te gebruiken voor enig ander doel dan het ontvangen van een audiosignaal van de bijbehorende draadloze microfoon.</p> <p>Dit apparaat maakt gebruik van frekwentiebanden welke in de Europese Gemeenschap (EG) niet algemeen zijn toegestaan. Afhankelijk van de geografische ligging kan voor het legaal gebruik van een bepaalde frekwentie een vergunning nodig zijn, zoals is aangegeven in de frekwentietabel.</p>
<b>BG</b>	Държава	<b>ВАЖНО УТОЧНЕНИЕ!</b>	<p>Не е законно използването на този приемник за каквато и да е друга цел, освен приемането на аудио сигнали от предвидения негов безжичен микрофон.</p> <p>Това устройство може да работи в честотен диапазон, нехармонизиран с изискванията на Европейската Общност (ЕС). В зависимост от конкретното географско място, само определени честоти могат да бъдат използвани легално – със или без оторизация / индивидуална лицензия, както е посочено в таблицата с честотите.</p>

 URL: [www.toa.eu](http://www.toa.eu)

02.06.2017



**INTENDED USE OF**
**WT-D5800**

<b>CY</b>	Κυπρος	<b>ΣΗΜΑΝΤΙΚΉ ΣΗΜΕΪΩΣΗ!</b>	<p>Είναι παράνομο να χρησιμοποιήσετε αυτό το δέκτη για οποιοδήποτε άλλο σκοπό εκτός από τη λήψη του ηχητικού σήματος από το αντιστοίχο ασύρματο μικρόφωνο.</p> <p>Η συσκευή αυτή κάνει χρήση των ζωνών συχνότητων οι οποίες δεν είναι εναρμονισμένες σε όλη την Ευρωπαϊκή Κοινότητα (ΕΕ). Ανάλογα με τη γεωγραφική περιοχή σε συγκεκριμένες συχνότητες μπορεί να χρησιμοποιηθεί νόμιμα, με ή χωρίς άδεια / ειδική άδεια, όπως αναφέρεται στον πίνακα συχνότητων.</p>
<b>CZ</b>	Česká republika	<b>DŮLEŽITÁ POZNÁMKA!</b>	<p>Tento přijímač bezdrátového mikrofonu smí být použit pouze pro přenos zvukového signálu z odpovídajícího bezdrátového mikrofonu. Jiné použití není legální.</p> <p>Toto zařízení používá frekvenční pásma, která nejsou harmonizována v celé Evropské Unii. V závislosti na lokalitě použití mohou být případně legálně použity pouze některé frekvence, viz tabulka frekvencí. K provozu může být vyžadováno povolení příslušných orgánů.</p>
<b>DK</b>	Danmark	<b>VIGTIGT!</b>	<p>Det er ulovligt at bruge denne modtager til andre formål end at modtage et lydsignal fra en passende trådløs mikrofon.</p> <p>Dette udstyr anvender frekvens bånd som ikke er harmoniseret i EU. Afhængig af det enkelte land/ område kan bestemte frekvenser anvendes lovligt med eller uden individuel licens som beskrevet i frekvens tabellen.</p>
<b>EE</b>	Eesti	<b>OLULINE TEADE!</b>	<p>Seda vastuvõtjat võib kasutada ainult vastava Toa saatjaga koostöös, muud kasutusviisid ei ole lubatud.</p> <p>Seadmega on võimalik kasutada Euroopa Liidus harmoniseerimata sagedusalasid, seega enne kasutamist tuleb kontrollida, et oleks valitud lubatud sagedused. Sõltuvalt geograafilisest asukohast võivad ainult teatud sagedusalad olla lubatud, võimalik, et nõutakse eraldi kasutuslubasid.</p>

 URL: [www.toa.eu](http://www.toa.eu)

02.06.2017

**INTENDED USE OF**
**WT-D5800**

<b>ES</b>	España	<b>¡ AVISO IMPORTANTE!</b>	<p>Es ilegal utilizar este receptor para cualquier otro propósito que no sea recibir una señal de audio de su correspondiente micrófono inalámbrico.</p> <p>Este dispositivo hace uso de bandas de frecuencia que no son legales en toda la Comunidad Europea (CE). Dependiendo del área geográfica, ciertas frecuencias se pueden utilizar legalmente, con o sin autorización individual, según se indica en la tabla de frecuencias.</p>
<b>FI</b>	Suomi / Finland	<b>HUOMIOITAVAA!</b>	<p>Tätä vastaanotinta saa käyttää ainoas-taan audiosignaalin vastaanottamiseen sille tarkoitulta langattomalta mikrofonilta.</p> <p>Tämä laite käyttää taajuuksia jotka eivät ole yhteneviä koko EU:n aluella. Riippuen maantieteelliestä sijainnista joitain taajuuksia saa käyttää joko radio-luvan kanssa tai ilman. Ks. oheinen taajuustaulukko.</p>
<b>UK IE</b>	United Kingdom Eire	<b>IMPORTANT NOTICE!</b>	<p>It is illegal to use this receiver for any other purpose than receiving an audio signal from its matching wireless microphone.</p> <p>This device makes use of frequency bands which are not harmonised throughout the European Community (EU). Depending on the geographical area certain frequencies can be used legally with or without authorisation / individual license as stated in the frequency table.</p>
<b>GR</b>	Ελλάδα	<b>ΣΗΜΑΝΤΙΚΗ ΣΗΜΕΙΩΣΗ!</b>	<p>Είναι παράνομη η χρήση του δέκτη για οποιοδήποτε άλλο λόγο εκτός της λήψης ηχητικού σήματος από το αντίστοιχο ασύρματο μικρόφωνο.</p> <p>Η συσκευή αυτή χρησιμοποιεί συχνότητες οι οποίες δεν εναρμονίζονται σε όλη την Ευρωπαϊκή Ένωση (Ε.Ε.). Ανάλογα με τη γεωγραφική περιοχή συγκεκριμένες συχνότητες μπορούν να χρησιμοποιηθούν νόμιμα με ή χωρίς άδεια / ειδική άδεια όπως αναφέρεται στον πίνακα συχνοτήτων.</p>
<b>HR</b>	Hrvatska	<b>Važne napomene</b>	<p>Korištenje prijemnika u bilo koju drugu svrhu, osim za primanje audio signala od pripadajućeg mu bežičnog mikrofona je ilegalno.</p> <p>Ovaj uređaj može koristiti frekvencije koji nisu u dozvoljene u svim zemljama Europske unije (EU). Ovisno o pojedinoj zemlji, određene frekvencije, legalno se mogu koristiti s ili bez dozvole/tj.individualne licence, a kako je navedeno u tablici s frekvencijama.</p>

 URL: [www.toa.eu](http://www.toa.eu)

02.06.2017

**INTENDED USE OF**
**WT-D5800**

<b>HU</b>	Magyarország	<b>FONTOS FIGYELMEZTETÉS!</b>	<p>Vevőegységek tervezett felhasználása</p> <p>Ez a vevőkészülék kizárólag hangjel fogadására alkalmazható a hozzá tartozó vezeték nélküli mikrofon felől. Egyéb felhasználási módja törvénybe ütközik.</p> <p>Ez az eszköz olyan frekvencia sávokat használ, amelyek nincsenek harmonizálva az Európai Közösségen (EU) belül. A földrajzi helyzettől függően csak bizonyos frekvenciák használhatók legálisan engedéllyel, vagy anélkül, a frekvencia táblázatban jelölteknek megfelelően.</p>
<b>IT CH</b>	Italia Svizzera	<b>AVVISO IMPORTANTE!</b>	<p>È illegale utilizzare questo ricevitore per qualsiasi altro scopo che non sia la ricezione di un segnale audio dal suo radiomicrofono.</p> <p>Questo prodotto utilizza bande di frequenza che non sono totalmente armonizzate in tutta la Comunità Europea (EU). Dipendentemente dall' area certe aree geografica certe frequenze possono essere usate legalmente con o senza autorizzazione / licenze individuali come stabilito nella tabella delle frequenze.</p>
<b>LT</b>	Lietuva	<b>SVARBI PASTABA!</b>	<p>Imtuvo naudojimo paskirtis</p> <p>Nelegalu naudoti šį imtuvą kitu tikslu, negu priimti garso signalą iš atitinkamo bevielio mikrofono.</p> <p>Šis įrenginys naudoja dažnių juostą kuri nėra suderinta su Europos sąjunga (ES). Priklausomai nuo geografinės vietovės, tik tam tikri dažniai gali būti naudojami teisėtai su arba be leidimo / individualios licencijos, kaip nurodyta dažnių lentelėje.</p>
<b>LV</b>	Latvija	<b>SVARĪGA PIEZĪME!</b>	<p>Uztvērēju paredzētā izmantošana</p> <p>Ir aizliegts izmantot šo uztvērēju jebkuram citam nolūkam, kā saņemt audio signālu no atbilstoša bezvadu mikrofona.</p> <p>Šī iekārta izmanto frekvenču joslas, kas nav saskaņotas visā Eiropas savienībā (ES). Atkarībā no ģeogrāfiskā reģiona tikai noteiktās frekvences var izmantot legāli, ar vai bez atļaujas vai individuālās licences, kā norādīts frekvenču tabulā.</p>

 URL: [www.toa.eu](http://www.toa.eu)

02.06.2017

**INTENDED USE OF**
**WT-D5800**

<b>MT</b>	Malta	<b>NOTA MPORTANTI!</b>	<p>Uzu tar-receivers</p> <p>Mhux permess l-uzu ta' dan ir-recievers, hliex biex jittrazmetti sinjal 'audio' lil microfonu tieghu. Kwalinkwe uzu ghal skop differenti, huwa illegali.</p> <p>Dan il-microphone jaghmel uzu minn frekwenzi li mhux ..... fl-Unjoni Ewropeja. F'certu zoni jistghu jigu ntuzati biss legalment certu frekwenzi bil- jew bla- awtorizzazzjoni jew licenzji li huma mhabbrin fuq il-'frequency table'.</p>
<b>NO</b>	Norway	<b>VIKTIG MELDING!</b>	<p>Det er ulovlig å bruke denne mottakeren til noe annet formål enn å motta et lydsignal fra en tilhørende trådløs mikrofon.</p> <p>Denne enheten gjør bruk av frekvensbånd som ikke gjennomført er harmonisert i det Europeiske Fellesskap (EU). Avhengig av det geografiske område kan noen frekvenser være tillatt brukt med eller uten autorisasjon / individuelle lisenser slik det er beskrevet i frekvenstabellen.</p>
<b>PL</b>	Polska	<b>WAŻNA INFORMACJA!</b>	<p>Używanie odbiornika bezprzewodowego w celu innym, niż odbiór sygnału audio ze sparowanego z nim nadajnika jest niezgodne z prawem.</p> <p>To urządzenie wykorzystuje pasma częstotliwości, które nie są zharmonizowane w obrębie Unii Europejskiej (UE). W zależności od lokalnych regulacji krajowych część częstotliwości może być niemożliwa do wykorzystania, lub też wymagać posiadania licencji, zgodnie z Krajową Tablicą Przeznaczeń Częstotliwości.</p>
<b>PT</b>	Portugal	<b>NOTA IMPORTANTE!</b>	<p>Este Receptor só pode receber sinal de audio do respectivo Microfone Emissor.</p> <p>Este equipamento utiliza bandas de frequência que não estão harmonizadas em toda a Comunidade Europeia (CEE). De acordo com a área geográfica, certas frequências podem ser usadas com ou sem autorização / licença individual, conforme está mencionada na lista de frequências.</p>

 URL: [www.toa.eu](http://www.toa.eu)

02.06.2017

**INTENDED USE OF**
**WT-D5800**

<b>RO</b>	Romania	<b>NOTA IMPORTANTA!</b>	<p>Este ilegala utilizarea acestui receptor in orice alt scop decat receptionarea unui semnal audio transmis de catre microfonul sau compatibil.</p> <p>Acest dispozitiv utilizeaza benzi de frecventa care nu sunt armonizate in Comunitatea Europeana (EU). In functie de asezarea geografica, numai anumite frecvente pot fi utilizate legal cu sau fara autorizatie/licenta individuala dupa cum se mentioneaza in tabelul de frecvente.</p>
<b>SE</b>	Sverige	<b>VIKTIG ANMÄRKNING!</b>	<p>Det är illegalt att använda denna mottagare för något annat ändamål än att ta emot en audiosignal från dess tillhörande trådlösa mikrofon.</p> <p>Denna apparat utnyttjar frekvensband som inte överensstämmer med varandra inom hela Europeiska Gemenskapen (EG). Beroende på geografiskt område kan vissa frekvenser användas legalt med eller utan tillstånd/individuell licens enligt frekvensplanen.</p>
<b>SI</b>	Slovenija	<b>POMEMBNO!</b>	<p>Prepovedana je vsakršna uporaba sprejemnika v druge namene kot sprejemanje avdio signala pripadajočega brezžičnega mikrofona.</p> <p>Ta naprava omogoča uporabo frekvenčnih pasov, ki niso usklajeni v vsej Evropski skupnosti (EU). Glede na geografsko območje se lahko legalno uporabljajo samo določene frekvence z ali brez dovoljenja, kot je navedeno v frekvenčni tabeli.</p>
<b>SK</b>	Štát	<b>DÔLEŽITÉ UPOZORNENIE!</b>	<p>Prijímač bezšnúrového mikrofónu sa nesmie používať na iný účel ako na príjem audio signálu z príslušného bezšnúrového mikrofónu.</p> <p>Toto zariadenie používa frekvenčné pásma, ktoré nie sú harmonizované v celej Európskej únii (EÚ). V závislosti od zemepisnej polohy možno používať len niektoré frekvencie na základe všeobecného alebo individuálneho povolenia, ako je uvedené vo frekvenčnej tabuľke.</p>

 URL: [www.toa.eu](http://www.toa.eu)

02.06.2017





**Traceability Information for USA**

Manufacturer:  
TOA Corporation  
7-2-1, Minatojima-Nakamachi, Chuo-ku, Kobe, Hyogo,  
Japan

Authorized representative:  
TOA Electronics, Inc.  
1 Harmon Plaza, Suite 700 Secaucus,  
New Jersey 07094,  
USA

**Traceability Information for Europe**

Manufacturer:  
TOA Corporation  
7-2-1, Minatojima-Nakamachi, Chuo-ku, Kobe, Hyogo,  
Japan

Authorized representative:  
TOA Electronics Europe GmbH  
Suederstrasse 282, 20537 Hamburg,  
Germany