



# CEILING MOUNT SPEAKER 6INCH 6W

PC-2360

## DESCRIPTION

The PC-2360 Ceiling Mount Speaker is of all metallic construction and ideal for use in a voice alarm system or BGM system. It feature spring clamp mechanism for easy mounting to the ceiling. The input impedance can be easily changed by changing the tap position of the transformer. The push-in type input terminal block makes cable connection easy and allow bridge wiring.

## SPECIFICATIONS

Rated Input	6 W (100 V line), 3 W (70 V line)
Rated Impedance	100 V line: 1.7 kΩ (6 W), 3.3 kΩ (3 W), 6.7 kΩ (1.5 W), 13 kΩ (0.8 W) 70 V line: 1.7 kΩ (3 W), 3.3 kΩ (1.5 W), 6.7 kΩ (0.8 W), 13 kΩ (0.4 W)
Sensitivity	94 dB (1 W, 1 m) (500 Hz - 5 kHz, pink noise)
Frequency Response	60 Hz - 20 kHz (peak -20 dB)
Speaker Component	16 cm (6") cone-type
Operating Temperature	-10 °C to +50 °C (14 °F to 122 °F)
Dimensions for Fixing Hole	Mounting hole: $\phi 200 \pm 3$ mm (7.87" $\pm$ 0.12") Ceiling thickness: 5 - 25 mm (0.2" - 0.98")
Speaker Mounting Method	Spring clamp
Applicable Cable	Solid wire: 0.5 - 3 mm <sup>2</sup> (AWG 20 - 12)
Connection	Push wire connection (Bridging terminal-2 branch type)
Finish	Frame: Steel plate, white (RAL 9016 equivalent), paint Grille: Steel net, white (RAL 9016 equivalent), paint
Dimensions	$\phi 230 \times 76$ (D) mm (9.06" $\times$ 2.99")
Weight	740 g (1.63 lb)
Accessory	Paper pattern ...1

## APPEARANCE

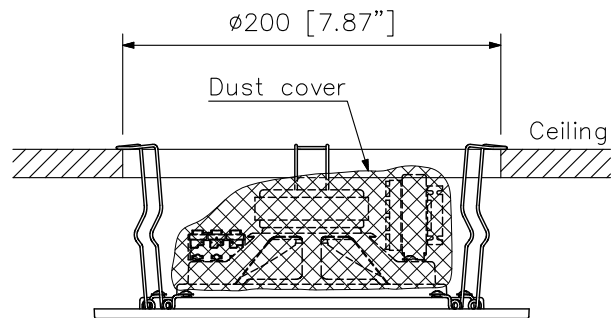
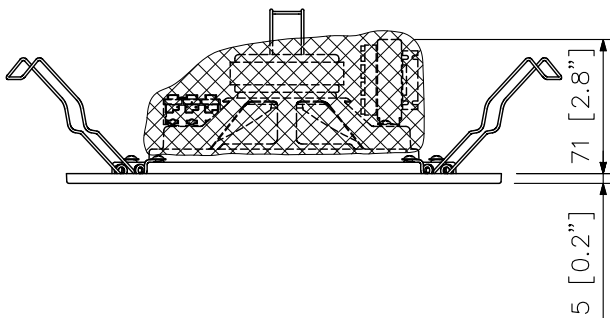

Mounting Diagram

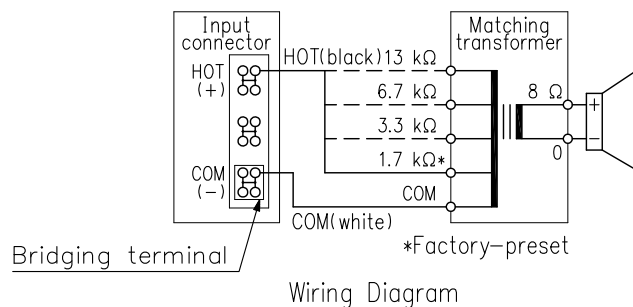
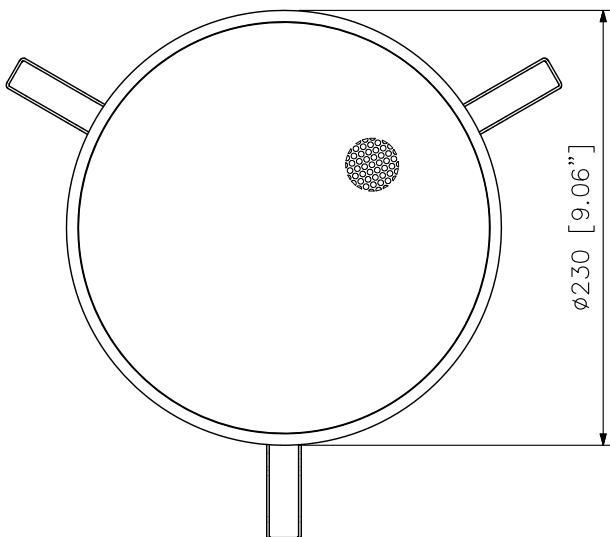

Wiring Diagram

Note: Use transformer terminals when changing input impedance.

UNIT: mm SCALE: 1/4