

ELX200-12SP 12" Powered Subwoofer

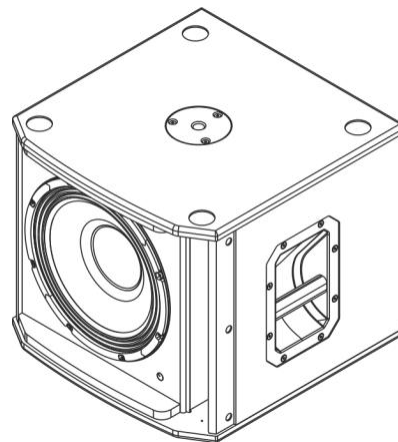

- EV Quick**Smart** Mobile application: quickly and wirelessly configure, control and monitor up to six ELX200 loudspeakers simultaneously, and receive immediate notification during critical performance conditions. *Bluetooth® is available in select countries.*
- Quick**Smart**DSP features best-in-class processing. Easy setup via three presets, sub/top system-match, five user-programmable presets, visual monitoring of limiter status, input level control and meters, and master volume control to optimize gain structure, all via LCD.
- High-efficiency 1200 W Class-D power amplifier delivers up to 129 dB peak SPL utilizing ultra-efficient, high-sensitivity transducer designed and engineered by EV.
- Ideal for portable and installed applications. Professional-grade hardware: integrated M20 threaded pole mount plate and two-handle design for easy lifting.

ELX200-12SP features high-efficiency Class-D power amplifiers (up to 1200 W) with integrated Quick**Smart**DSP, and delivers up to 129 dB SPL utilizing transducers designed and engineered by EV (12-inch EVS-12L woofer). Powered subwoofer models allow easy setup via three presets (Music, Live, Club), sub/top system-match crossovers, three-band EQ, five user-programmable presets (Store and Recall settings), visual monitoring of limiter status, input level control and meters, and master volume control to ensure optimal gain structure. ELX200 powered models are ideal for portable and installed applications, with lightweight and compact 15-mm wood enclosures, integrated M20 threaded pole pole-mount plate, and two-handle design for easy lifting. The new Quick**Smart** Mobile wireless control and monitoring application, using Bluetooth® Low Energy (BTLE) technology, allows intuitive system control, configuration and monitoring of up to six powered ELX200 loudspeakers simultaneously. Receive alerts



when your system is being overdriven, and control your system while *in front* of your speakers, not behind. *Bluetooth® is available in select countries.*

Technical specifications

Frequency response (-3 dB):	49 Hz - 135 Hz
Frequency range (-10 dB):	41 Hz - 165 Hz
Maximum SPL ₂ :	129 dB
Power rating:	1200 W
LF transducer:	EVS-12L 300 mm (12 in)
Low-Pass frequency:	Adjustable: 80 Hz, 100 Hz, 120 Hz, 150 Hz
Connectors:	(2) XLR/TRS combo jacks and (2) XLR link outputs
Enclosure:	15 mm plywood with EVCoat

2 | ELX200-12SP 12" Powered Subwoofer

Grille:	18 AWG steel with powdercoat
Color:	Black or white
Dimensions (H x W x D):	397 mm x 445 mm x 457 mm (16.7 in x 17.6 in x 18.0 in)
Net weight:	19.1 kg (42.2 lb)
Shipping weight:	22.3 kg (49.2 lb)
Power consumptions:	100 - 240 V~, 50 - 60 Hz, 1.8 A

- 1 Full-space measurement using music DSP preset.
- 2 Maximum SPL is measured at 1 m using broadband pink noise at maximum output.
- 3 Current rating is 1/8 power.

Dimensions:

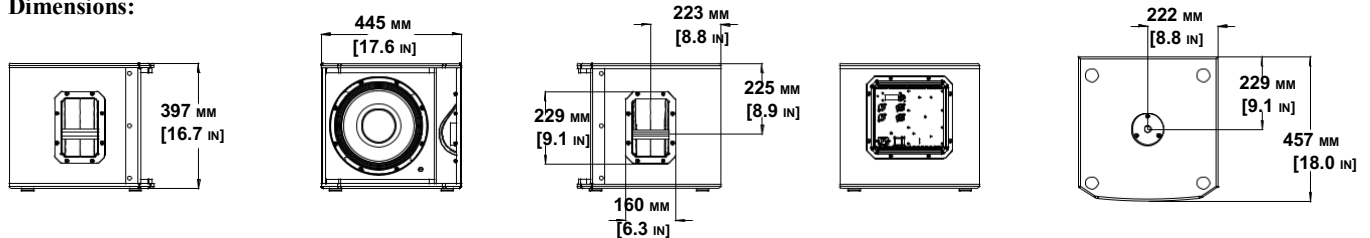

System overview

Subwoofer amplifier panel:

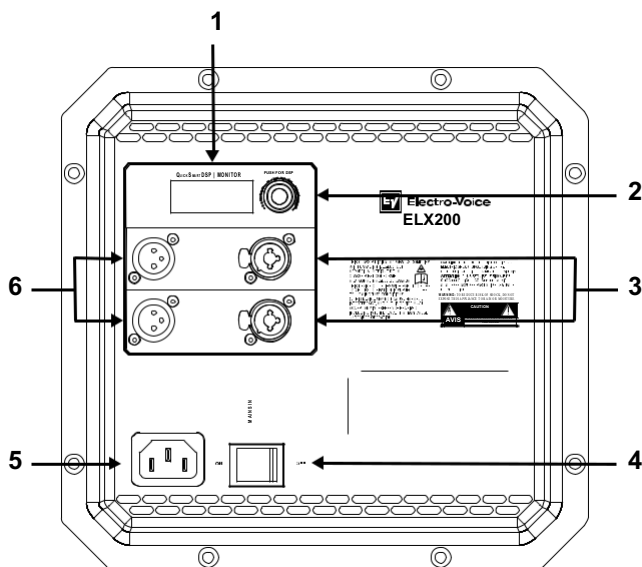

1. **LCD** - DSP control and monitoring interface.
2. **MASTER VOL** - Adjusts the sound level.
DSP - Scroll through the menu and select the available choices. Push the MASTER VOL knob to enter the DSP menu.
3. **INPUT** - Balanced input for the connection of signal sources like mixing consoles, instruments, or microphones. Connections can be established using ¼ inch TRS or XLR connectors.
4. **POWER** - AC switch for switching the power ON or OFF. The LCD screen lights up when the power is turned ON, after approximately 3 seconds.

Frequency response:

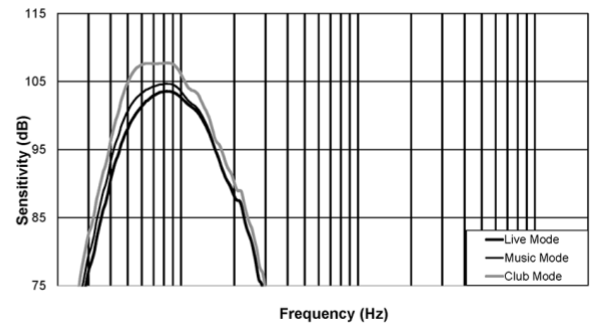

5. **MAINS IN** - AC connection is established via an IEC-connector.
6. **OUTPUT** - XLR output sends the input signal to another loudspeaker or subwoofer. INPUT 1 is linked to OUTPUT 1 and INPUT 2 is linked to OUTPUT 2. The MASTER VOL or DSP control settings do not affect OUTPUT.

For more information, see ELX200 Powered Loudspeakers Installation manual (F.01U.326.891).

Ordering information

ELX200-12SP-US 12" powered subwoofer, US cord
Powered 12-inch subwoofer US cord, black
Order number ELX200-12SP-US

ELX200-12SP-EU 12" powered subwoofer, EU cord
Powered 12-inch subwoofer EU cord, black
Order number ELX200-12SP-EU

ELX200-12SP-AP 12" powered subwoofer, AP
Powered 12-inch subwoofer Asia-Pacific regions, black
Order number ELX200-12SP-AP

ELX200-12SP-GL 12" powered subwoofer, Global, No BT
Powered 12-inch subwoofer two cords, No Bluetooth®, black
Order number ELX200-12SP-GL

ELX200-12SP-W 12" powered subwoofer, white
12" powered subwoofer, white
Order number ELX200-12SP-W

Accessories

ELX200-12S-CVR Padded cover for ELX200-12S, 12SP

Padded cover for ELX200-12S/12SP, black

Order number **ELX200-12S-CVR**

Represented by:

Germany:
Bosch Sicherheitssysteme GmbH
Robert-Bosch-Ring 5 85630
Grasbrunn Germany

Bosch Security Systems, Inc.
12000 Portland Avenue South
Burnsville MN 55337
USA

www.trungchinhaudio.vn