

www.trungchinhaudio.vn

## Overview

---

MG10XU is a versatile mixer suitable for a wide range of users and applications.



Rear Panel

## Features

---

- Input channels: 10 Line Inputs (4 mono, 3 stereo), 4 Mic Inputs with 48V phantom power and HPH per channel.
- Output channels: 2 ST, 1 MONITOR, 1 AUX[FX] send, 1 PHONES.
- Bus: 1 ST, 1 AUX[FX]
- Robust, impact-resistant, powder-coated metal chassis.
- AC Adapter PA-10 (AC 38VCT, 0.62A) or equivalent recommended by Yamaha.
- Discrete class A "D-PRE" mic preamps with an inverted darlington circuit.
- Professional "1-knob compressors" with LED indicators.
- Digital effects processors: 24 "SPX" effects

## Specifications

1/2

### General Specifications

INPUT CHANNELS	LINE INPUT	10 (4 MONO + 3 STEREO)
	MIC INPUT	4
	MONO INPUT (MIC/LINE)	4 (CH1-4)
	MONO/STEREO INPUT (MIC/LINE)	0
	STEREO INPUT (LINE)	3
OUTPUT CHANNELS	STEREO OUT	2
	MONITOR OUT	1
	AUX SEND	1
	GROUP OUT	0
	PHONES OUT	1
BUS	STEREO	1
	GROUP	0
	AUX	1 (incl.FX)
USB AUDIO - USB IN/OUT	Yes (2 IN / 2 OUT, USB Audio Class 2.0 compliant, Sampling Frequency: Max 192kHz, Bit Depth: 24-bit)	
PHANTOM POWER	+48V	
POWER REQUIREMENTS	May vary depending on region (120/60Hz, 220V/60Hz, 220V/50Hz, 230V/50Hz, 240V/50Hz)	
POWER SUPPLY TYPE	AC Adapter PA-10 (AC 38VCT, 0.62A) or equivalent recommended by Yamaha	
POWER CONSUMPTION	22.9W	
DIMENSIONS	W x D x H	244mm x 294mm x 71mm (9.6" x 11.6" x 2.8")
NET WEIGHT	2.1kg (4.63lbs)	
INCLUDED ACCESSORIES	AC Adaptor, Owner's manual, Technical Specifications, Cubase AI Download Information	
SOFTWARE APPLICATION	Steinberg CUBASE AI	Yes (Download access code included. Download on the Steinberg web site)
	Steinberg CUBASIS LE	Yes (Download on the App Store) (Apple iPad Camera Connection Kit/Lightening to USB Camera Adapter required)
	MG REC/PLAY (WAV)	Yes (Download on the App Store) (Apple iPhone/iPad Camera Connection Kit/Lightening to USB Camera Adapter required)
OPTIONAL ACCESSORIES	BMS-10A Mic Stand Adaptor, FC5 Foot Switch	
OPERATING TEMPERATURE	0 to 40°C	

### Featured Functions

D-PRE MIC PREAMP	Yes
1-KNOB COMP	Yes
SPX DIGITAL EFFECTS	Yes (24 programs. REV HALL 1 / REV HALL 2 / REV ROOM 1 / REV ROOM 2 / REV STAGE 1 / REV STAGE 2 / REV PLATE / DRUM AMB / EARLY REF / GATE REV / SINGLE DLY / DELAY / VOCAL ECHO / KARAOKE / PHASER / FLANGER / CHORUS 1 / CHORUS 2 / SYMPHONIC / TREMOLO / AUTO WAH / RADIO VOICE / DISTORTION / PITCH CHANGE)

### Electrical Specifications

TOTAL HARMONIC DISTORTION	+14dBu (20Hz to 20kHz)	0.02%
	Gain knob: Min +24dBu (1kHz) Gain knob: Min	0.003%
FREQUENCY RESPONSE	+0.5/-1.0dB (20Hz - 48kHz), refer to the nominal output level @1kHz, GAIN knob: Min	
HUM & NOISE LEVEL	Equivalent input noise	-128 dBu (Mono Input Channel, Rs: 150Ω, Gain knob: Max)
	Residual output noise	-102 dBu (STEREO OUT, STEREO LEVEL knob: Min)
CROSSTALK	@ 1kHz	-83dB
INPUT CHANNEL FUNCTION	PAD	26dB
	HPH	80Hz, 12dB/oct (Mono)
	COMP	1 knob compressor Threshold: +22dBu to -8dBu, Ratio: 1:1 to 4:1 Output level: 0dB to 7dB Attack time: approx. 25msec Release time: approx. 300msec
	High	±15dB (10kHz shelving)
	Mid	±15dB (2.5kHz peaking)
	Low	±15dB (100Hz shelving)
LED LEVEL METER	Pre Monitor Level	2 x 7 points LED meter (PEAK, +10, +6, 0, -6, -10, -20dB)
PEAK LED	LED turns on when post EQ signal reaches 3dB below clipping level	

## Specifications

2/2

### Analog Input Characteristics

INPUT TERMINAL	PAD 26dB	GAIN TRIM POSITION	ACTUAL LOAD IMPEDANCE	FOR USE WITH NOMINAL	INPUT LEVEL			CONNECTOR
					Sensitivity*1	Nominal	Max. before clip	
MIC/LINE 1 - 4	OFF	+64 dB	3kΩ	50-600Ω Mics/Lines	-72 dBu (0.195 mV)	-60 dBu (0.775 mV)	-40 dBu (7.75 mV)	Combo jack*2 (Balanced)
		+20 dB			-28 dBu (30.9 mV)	-16 dBu (122.8 mV)	+4 dBu (1.228 V)	
	ON	+38 dB			-46 dBu (3.884 mV)	-34 dBu (15.46 mV)	-14 dBu (154.6 mV)	
		-6 dB			-2 dBu (615.6 mV)	+10 dBu (2.451 V)	+30 dBu (24.51 V)	
LINE 5/6 - 7/8	-	-	10kΩ	600Ω	-22 dBu (61.56 mV)	-10 dBu (245.1 mV)	+10 dBu (2.451 V)	Phone jack*5 RCA Pin (Unbalanced)
LINE 9/10	-	-	-	Lines	-	-	-	Phone jack*5 (Unbalanced)

### Analog Output Characteristics

OUTPUT TERMINALS	ACTUAL SOURCE IMPEDANCE	FOR USE WITH NOMINAL	OUTPUT LEVEL		CONNECTOR
			Nominal	Max. before clip	
STEREO OUT [L, R]	75Ω	600Ω Lines +20dB	+4 dBu (1.228 V)	+24 dBu (12.28 V)	XLR-3-32*3 Phone jack*5 (Balanced)
MONITOR OUT [L, R], AUX [FX] SEND	150Ω	10kΩ Lines	+4 dBu (1.228 V)	+20 dBu (7.750 V)	Phone jack*4 (Impedance Balanced)
PHONES	110Ω	40Ω Phones	3mW+3mW	100mW+100mW	Stereo phone jack

### Digital Input/Output Characteristics / MG10XU

OUTPUT TERMINALS	FORMAT	DATA LENGTH	Fs	CONNECTOR
USB	USB Audio Class 2.0	16 / 24bit	44.1 kHz, 48 kHz, 88.2 kHz, 96 kHz, 176.4kHz, 192 kHz	USB Standard-B

0dBu is referenced to 0.775Vrms.

\*1 Sensitivity is the lowest level that will produce an output of +4dBu (1.228V) or the nominal output level when the unit is set to maximum gain. (All level controls are maximum position.)

\*2 1&Sleeve = GND, 2&Tip = HOT, 3&Ring = COLD

\*3 1 = GND, 2 = HOT, 3 = COLD

\*4 Tip = HOT, Ring = COLD, Sleeve = GND

\*5 Tip = Signal, Sleeve = GND

## Dimensions

Unit: mm (inch)

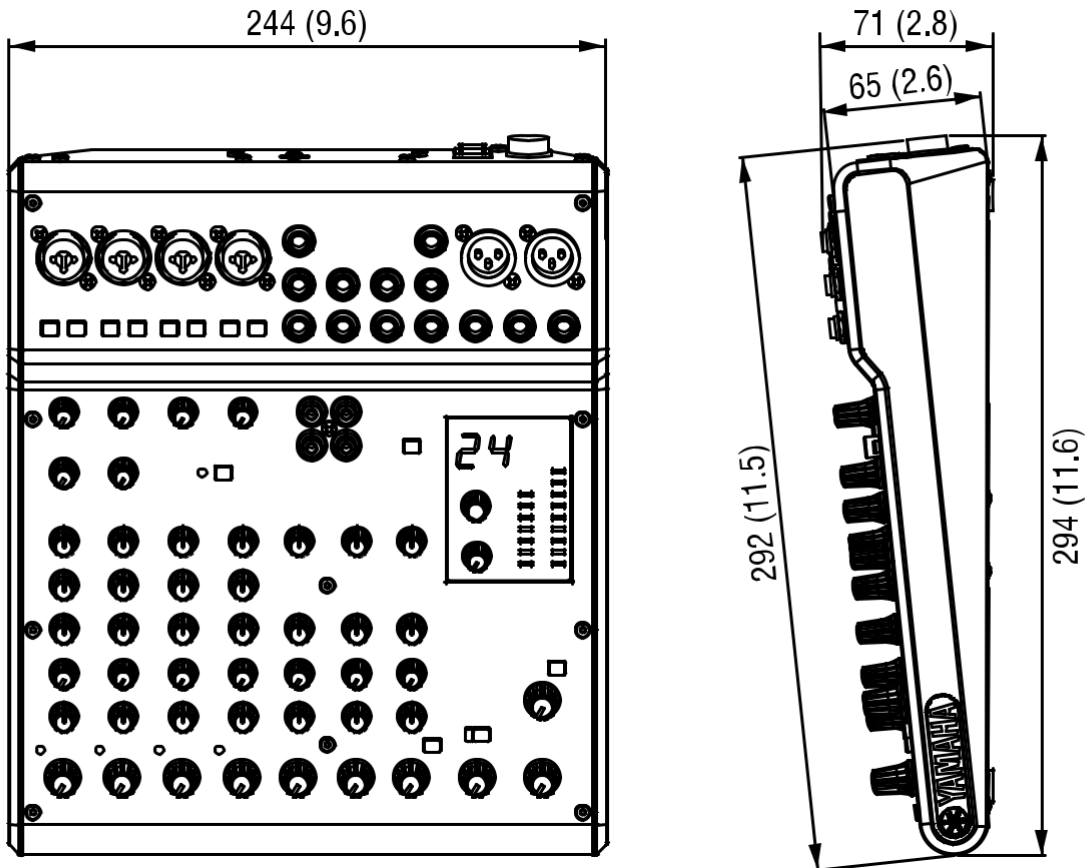

## Options

- Mic Stand Adaptor      BMS-10A
- Foot Switch              FC5

## Software

- MG REC/PLAY
- Steinberg Cubase AI
- Steinberg Cubasis LE

## Architectural and Engineering Specifications

---

The Yamaha MG10XU Mixing Console shall be a versatile 10-channel mixer that is suitable for a wide range of users and applications. The MG10 shall have 10 line inputs (4 mono, 3 stereo) and 4 microphone inputs with 48-volt phantom power and a high-pass filter for each channel. Two stereo outputs, one monitor output, one auxiliary (effects) send, and one headphone output shall be provided. One stereo bus and one auxiliary (effects) bus shall be provided. The mixing console's microphone preamplifiers shall be discrete class-A "D-PRE" types for high sound quality. Yamaha's 1-knob compressors with LED indicators shall be included for easy compression control. A digital effects processor with 24 high-quality "SPX" effects shall be included to allow creative sound processing. The mixing console shall be equipped with a 24-bit/192-kHz 2-in/2-out USB digital audio interface, and shall be supplied with an access code that will allow Cubase AI music production software to be downloaded from the Steinberg website. Steinberg's Cubasis LE multi-touch sequencer for the iPad and Yamaha's MG Rec&Play recording application for the iPad and iPhone shall be available for download from the App Store at no charge. The mixing console shall be robust and built into an impact-resistant powder-coated metal chassis. The mixing console shall be powered by a Yamaha PA10 AC adapter, or equivalent. Dimensions shall be 244 (W) x 294 (D) x 71mm (H) (9.6" x 11.6" x 2.8"). Weight shall be 2.1kg (4.63lbs).

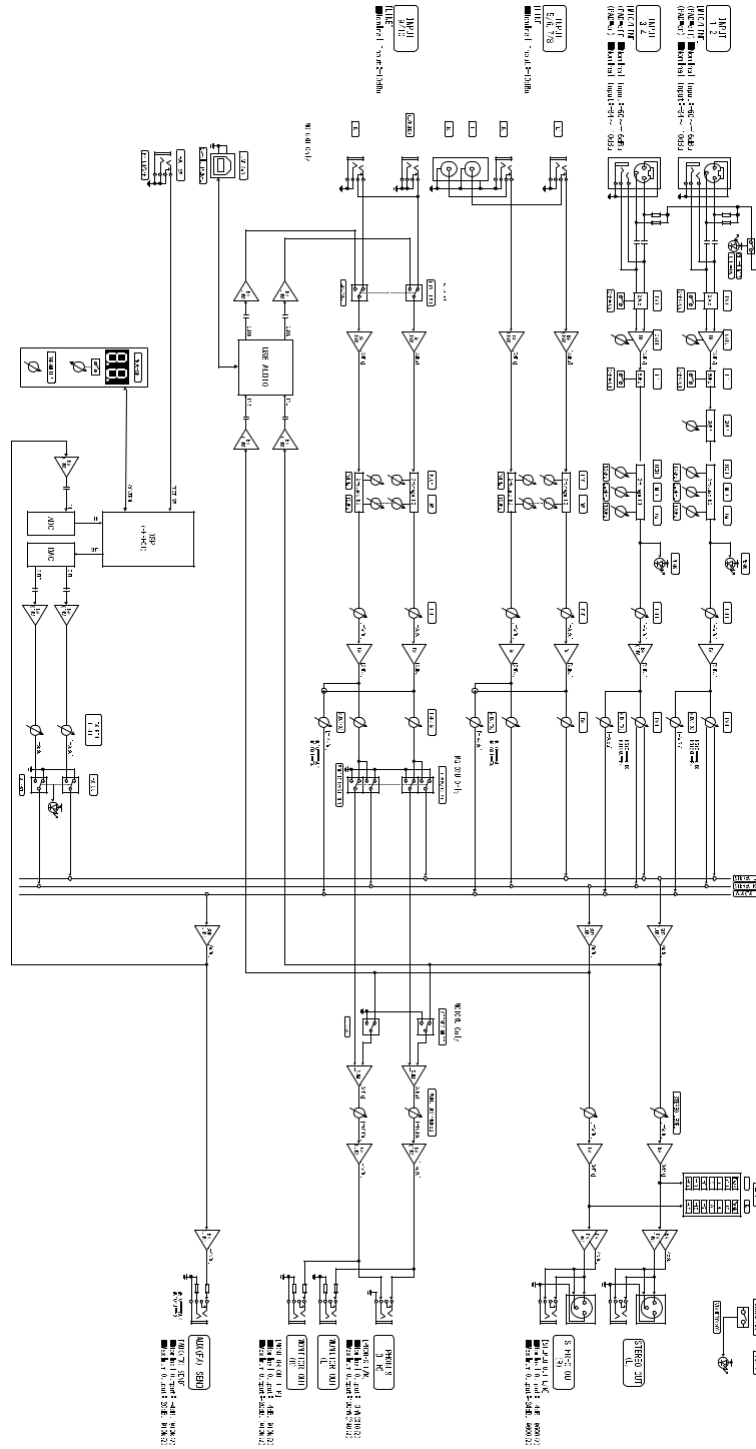
**Block Diagrams**

\*All information subject to change without notice.

\*All trademarks and registered trademarks are property of their respective owners.

Created in March, 2017

**YAMAHA CORPORATION**  
 P.O.BOX 1, Hamamatsu Japan  
[www.yamahaproaudio.com](http://www.yamahaproaudio.com)